

A Course Material on

CIRCUIT THEORY



By

Mr. ASHUTOSH MISHRA

LECTURER

DEPARTMENT OF ELECTRICAL ENGINEERING

NMDC DAV POLYTECHNIC

GEEDEAM, DANTEWADA

OBJECTIVES:

- To introduce electric circuits and its analysis
- To impart knowledge on solving circuits using network theorems
- To introduce the phenomenon of resonance in coupled circuits.
- To educate on obtaining the transient response of circuits.
- To Phasor diagrams and analysis of three phase circuits

UNIT I BASIC CIRCUITS ANALYSIS

Ohm's Law – Kirchhoff's laws – DC and AC Circuits – Resistors in series and parallel circuits – Mesh current and node voltage method of analysis for D.C and A.C. circuits – Phasor Diagram – Power, Power Factor and Energy

UNIT II NETWORK REDUCTION AND NETWORK THEOREMS FOR DC AND AC CIRCUITS

Network reduction: voltage and current division, source transformation – star delta conversion. Thevenin's and Norton & Theorem – Superposition Theorem–Maximum power transfer theorem –Reciprocity Theorem.

UNIT III RESONANCE

Series and parallel resonance – their frequency response – Quality factor and Bandwidth -.

UNIT IV THREE PHASE CIRCUITS

Three phase balanced / unbalanced voltage sources – analysis of three phase 3-wire and 4-wire circuits with star and delta connected loads, balanced & un balanced – phasor diagram of voltages and currents – power and power factor measurements in three phase circuits.

TEXT BOOKS:

1. William H. Hayt Jr, Jack E. Kemmerly and Steven M. Durbin, "Engineering Circuits Analysis", Tata McGraw Hill publishers, 6th edition, New Delhi, 2003.
2. Joseph A. Edminister, Mahmood Nahri, "Electric circuits", Schaum's series, Tata McGraw-Hill, New Delhi, 2001.

REFERENCES:

1. Paranjothi SR, "Electric Circuits Analysis," New Age International Ltd., New Delhi, 1996.
2. Sudhakar A and Shyam Mohan SP, "Circuits and Network Analysis and Synthesis", Tata McGrawHill, 2007.
3. Chakrabati A, "Circuits Theory (Analysis and synthesis), Dhanpath Rai & Sons, New Delhi, 1999.
4. Charles K. Alexander, Mathew N.O. Sadiku, "Fundamentals of Electric Circuits", Second Edition, McGraw Hill, 2003.

SL. NO.	CONTENTS	PAGE NO
UNIT I BASIC CIRCUITS ANALYSIS		6
1.1.	INTRODUCTION:	6
1.2.	BASIC ELEMENTS & INTRODUCTORY CONCEPTS:	6
1.3.	KIRCHOFF'S LAW	7
1.4.	PROBLEMS AND CALCULATIONS:	9
1.5.	DC CIRCUITS:	12
1.6.	AC CIRCUITS:	12
1.7.	DIFFERENCE BETWEEN AC AND DC:	13
1.8.	PARALLEL NETWORKS:	15
1.9.	MESH ANALYSIS:	17
1.10.	NODAL ANALYSIS:	24
QUESTION BANK		36
UNIT II NETWORK REDUCTION AND NETWORK THEOREMS FOR DC AND AC CIRCUITS		42
2.1.	NETWORK REDUCTION:	42
2.2.	VOLTAGE AND CURRENT DIVISION:	42
2.3.	POTENTIAL DIVIDER:	42
2.4.	VOLTAGE SOURCE TO CURRENT SOURCE TRANSFORMATION:	47
2.5.	CURRENT SOURCE TO VOLTAGE SOURCE TRANSFORMATION:	47
2.6.	STAR DELTA CONVERSION:	47
2.7.	THEVENIN'S THEOREM:	51
2.8.	NORTON'S THEOREM:	57
QUESTION BANK		60
UNIT III RESONANCE AND COUPLED CIRCUITS		66
3.1.	SERIES AND PARALLEL RESONANCE THEIR FREQUENCY RESPONSE	66
3.2.	QUALITY FACTOR AND BANDWIDTH	67
QUESTION BANK		109
UNIT – V ANALYSING THREE PHASE CIRCUITS		138
5.1.	INTRODUCTION:	
5.2.	PHASOR DIAGRAM OF THREE PHASE SUPPLY:	
QUESTION BANK		
MODEL QUESTION PAPERS		

UNIT I BASIC CIRCUITS ANALYSIS

Ohm's Law – Kirchoffs laws – DC and AC Circuits – Resistors in series and parallel circuits – Meshcurrent and node voltage method of analysis for D.C and A.C. circuits – Phasor Diagram – Power, Power Factor and Energy

1.1. INTRODUCTION:

The interconnection of various electric elements in a prescribed manner comprises as an electric circuit in order to perform a desired function. The electric elements include controlled and uncontrolled source of energy, resistors, capacitors, inductors, etc. Analysis of electric circuits refers to computations required to determine the unknown quantities such as voltage, current and power associated with one or more elements in the circuit. To contribute to the solution of engineering problems one must acquire the basic knowledge of electric circuit analysis and laws. Many other systems, like mechanical, hydraulic, thermal, magnetic and power system are easy to analyze and model by a circuit. To learn how to analyze the models of these systems, first one needs to learn the techniques of circuit analysis. We shall discuss briefly some of the basic circuit elements and the laws that will help us to develop the background of subject.

1.2. BASIC ELEMENTS & INTRODUCTORY CONCEPTS:

Electrical Network:

A combination of various electric elements (Resistor, Inductor, Capacitor, Voltage source, Current source) connected in any manner what so ever is called an electrical network. We may classify circuit elements in two categories, passive and active elements.

Passive Element:

The element which receives energy (or absorbs energy) and then either converts it into heat (R) or stored it in an electric (C) or magnetic (L) field is called passive element.

Active Element:

The elements that supply energy to the circuit is called active element. Examples of active elements include voltage and current sources, generators, and electronic devices that require power supplies. A transistor is an active circuit element, meaning that it can amplify power of a signal. On the other hand, transformer is not an active element because it does not amplify the power level and power remains same both in primary and secondary sides. Transformer is an example of passive element.

Bilateral Element:

Conduction of current in both directions in an element (example: Resistance; Inductance; Capacitance) with same magnitude is termed as bilateral element.

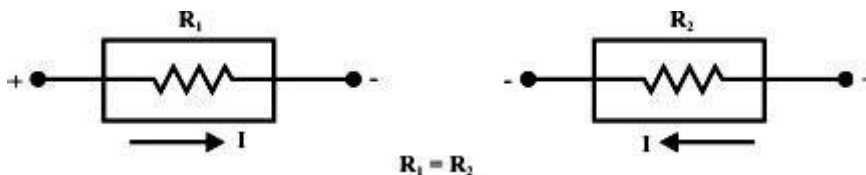

Unilateral Element:

Conduction of current in one direction is termed as unilateral (example: Diode, Transistor) element.

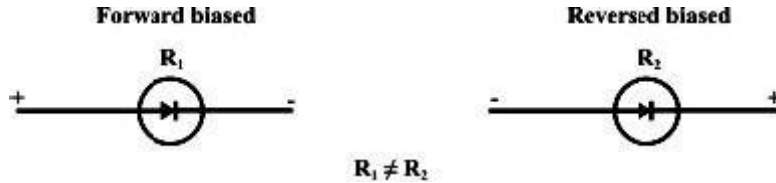

Meaning of Response:

An application of input signal to the system will produce an output signal, the behavior of output signal with time is known as the response of the system.

Potential Energy Difference:

The voltage or potential energy difference between two points in an electric circuit is the amount of energy required to move a unit charge between the two points.

Ohm's Law: Ohm's law states that the current through a conductor between two points is directly proportional to the potential difference or voltage across the two points, and inversely proportional to the resistance between them. The mathematical equation that describes this relationship is:

$$I = \frac{V}{R}$$

where I is the current through the resistance in units of amperes, V is the potential difference measured across the resistance in units of volts, and R is the resistance of the conductor in units of ohms. More specifically, Ohm's law states that the R in this relation is constant, independent of the current.

1.3. KIRCHOFF'S LAW

Kirchoff's First Law - The Current Law, (KCL)

"The total current or charge entering a junction or node is exactly equal to the charge leaving the node as it has no other place to go except to leave, as no charge is lost within the node".

In other words the algebraic sum of ALL the currents entering and leaving a node must be equal to zero,

$$I(\text{exiting}) + I(\text{entering}) = 0.$$

This idea by Kirchoff is known as the Conservation of Charge.

Currents Entering the Node
=

Currents Leaving the Node

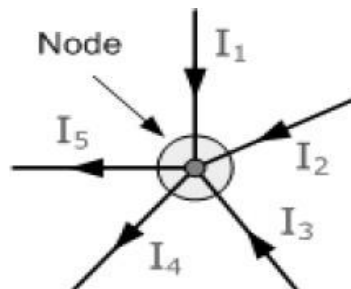

$$I_1 + I_2 + I_3 = I_4 + I_5 = 0$$

Here, the 3 currents entering the node, I_1 , I_2 , I_3 are all positive in value and the 2 currents leaving the node, I_4 and I_5 are negative in value.

Then this means we can also rewrite the equation as;

$$I_1 + I_2 + I_3 - I_4 - I_5 = 0$$

Kirchoff's Second Law - The Voltage Law, (KVL)

"In any closed loop network, the total voltage around the loop is equal to the sum of all the voltage drops within the same loop" which is also equal to zero. In other words the algebraic sum of all voltages within the loop must be equal to zero. This idea by Kirchoff is known as the Conservation of Energy.

Starting at any point in the loop continue in the same direction noting the direction of all the voltage drops, either positive or negative, and returning back to the same starting point. It is important to maintain the same direction either clockwise or anti-clockwise or the final voltage sum will not be equal to zero.

We can use Kirchoff's voltage law when analyzing series circuits.

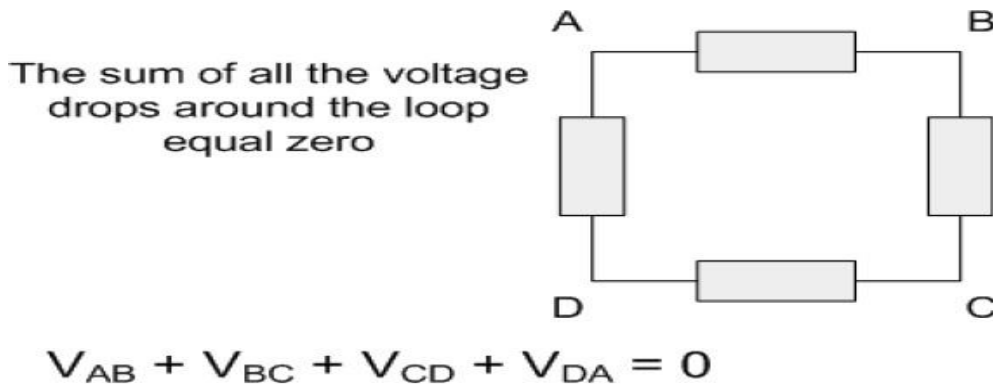

1.4.**PROBLEMS AND CALCULATIONS:****Problem 1:**

A current of 0.5 A is flowing through the resistance of 10Ω. Find the potential difference between its ends.

Solution: Current I = 0.5A. Resistance R = 10Ω Potential difference V =?

$$\begin{aligned} V &= IR \\ &= 0.5 \times 10 \\ &= 5V. \end{aligned}$$

Problem: 2

A supply voltage of 220V is applied to a 100 Ω resistor. Find the current flowing through it.

Solution:

$$\begin{aligned} \text{Voltage } V &= 220V \text{ Resistance } R = 100\Omega \\ \text{Current } I &= V / R \\ &= 220 / 100 \\ &= 2.2 \text{ A.} \end{aligned}$$

Problem: 3

Calculate the resistance of the conductor if a current of 2A flows through it when the potential difference across its ends is 6V.

Solution:

$$\begin{aligned} \text{Current } I &= 2A. \\ \text{Potential difference } = V &= 6. \\ \text{Resistance } R &= V / I \\ &= 6 / 2 \\ &= 3 \text{ ohm.} \end{aligned}$$

Problem: 4

Calculate the current and resistance of a 100 W, 200V electric bulb.

Solution:

$$\text{Power, } P = 100W$$

$$\text{Voltage, } V = 200V \text{ Power}$$

$$P = VI$$

$$\text{Current } I = P / V$$

$$= 100 / 200$$

$$= 0.5A$$

$$\text{Resistance } R = V / I$$

$$= 200 / 0.5$$

$$= 400W.$$

Problem: 5

Calculate the power rating of the heater coil when used on 220V supply *taking 5 Amps*.

Solution:

$$\begin{aligned} \text{Voltage, } V &= 220\text{V} \\ \text{Current, } I &= 5\text{A,} \\ \text{Power, } P &= VI \\ &= 220 \times 5 \\ &= 1100\text{W} \\ &= 1.1 \text{ KW.} \end{aligned}$$

Problem: 6

A circuit is made of 0.4Ω wire, a 150Ω bulb and a 120Ω rheostat *connected in series*. Determine the total resistance of the resistance of the circuit.

Solution:

$$\text{Resistance of the wire} = 0.4\Omega \quad \text{Resistance of bulb} = 150 \Omega \quad \text{Resistance of rheostat} = 120\Omega$$

In series,

$$\begin{aligned} \text{Total resistance, } R &= 0.4 + 150 + 120 \\ &= 270.4\Omega \end{aligned}$$

Problem : 7

Three resistances of values 2Ω , 3Ω and 5Ω are connected in series across 20 V,D.C supply .Calculate (a) equivalent resistance of the circuit (b) the total current of the circuit (c) the voltage drop across each resistor and (d) the power dissipated in each resistor.

Solution:

$$\begin{aligned} \text{Total resistance } R &= R_1 + R_2 + R_3. \\ &= 2 + 3 + 5 = 10\Omega \end{aligned}$$

$$\text{Voltage} = 20\text{V}$$

$$\text{Total current } I = V/R = 20/10 = 2\text{A.}$$

$$\begin{aligned} \text{Voltage drop across } 2\Omega \text{ resistor } V_1 &= I R_1 \\ &= 2 \times 2 = 4 \text{ volts.} \end{aligned}$$

$$\begin{aligned} \text{Voltage drop across } 3\Omega \text{ resistor } V_2 &= I R_2 \\ &= 2 \times 3 = 6 \text{ volts.} \end{aligned}$$

$$\begin{aligned} \text{Voltage drop across } 5\Omega \text{ resistor } V_3 &= I R_3 \\ &= 2 \times 5 = 10 \text{ volts.} \end{aligned}$$

$$\begin{aligned} \text{Power dissipated in } 2\Omega \text{ resistor is } P_1 &= I^2 R_1 \\ &= 2^2 \times 2 = 8 \text{ watts.} \end{aligned}$$

$$\begin{aligned} \text{Power dissipated in } 3 \text{ resistor is } P_2 &= I^2 R_2. \\ &= 2^2 \times 3 = 12 \text{ watts.} \end{aligned}$$

$$\text{Power dissipated in } 5 \text{ resistor is } P_3 = I^2 R_3$$

$$= 2^2 \times 5 = 20 \text{ watts.}$$

Problem: 8

A lamp can work on a 50 volt mains taking 2 amps. What value of the resistance must be connected in series with it so that it can be operated from 200 volt mains giving the same power.

Solution:

Lamp voltage, $V = 50\text{V}$ Current, $I = 2$ amps.

Resistance of the lamp $= V/I = 50/2 = 25 \Omega$

Resistance connected in series with lamp $= r$.

Supply voltage $= 200$ volt.

Circuit current $I = 2\text{A}$

Total resistance $R_t = V/I = 200/2 = 100\Omega$

$$R_t = R + r \quad 100 = 25 + r$$

$$r = 75\Omega$$

Problem: 9

Find the current flowing in the 40Ω Resistor, R_3

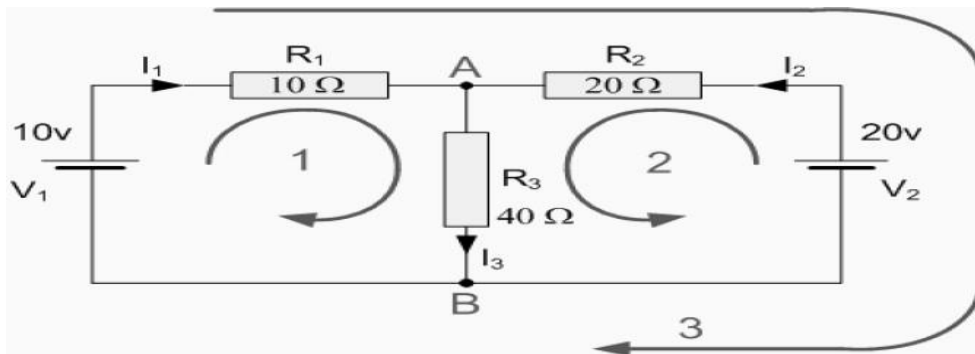
**Solution:**

The circuit has 3 branches, 2 nodes (A and B) and 2 independent loops.

Using Kirchoff's Current Law, KCL the equations are given as;

At node A: $I_1 + I_2 = I_3$

At node B: $I_3 = I_1 + I_2$

Using Kirchoff's Voltage Law, KVL the equations are given as;

Loop 1 is given as: $10 = R_1 \times I_1 + R_3 \times I_3 = 10I_1 + 40I_3$

Loop 2 is given as: $20 = R_2 \times I_2 + R_3 \times I_3 = 20I_2 + 40I_3$

Loop 3 is given as: $10 - 20 = 10I_1 - 20I_2$

As I_3 is the sum of $I_1 + I_2$ we can rewrite the equations as;

Eq. No 1: $10 = 10I_1 + 40(I_1 + I_2) = 50I_1 + 40I_2$

Eq.No 2: $20 = 20I_1 + 40(I_1 + I_2) = 40I_1 + 60I_2$

We now have two "Simultaneous Equations" that can be reduced to give us the value of both I_1 and I_2

Substitution of I_1 in terms of I_2 gives us the value of I_1 as -0.143 Amps

Substitution of I_2 in terms of I_1 gives us the value of I_2 as $+0.429$ Amps

As: $I_3 = I_1 + I_2$

The current flowing in resistor R_3 is given as: $-0.143 + 0.429 = 0.286$ Amps

and the voltage across the resistor R_3 is given as : $0.286 \times 40 = 11.44$ volts

Problem: 10

Find the current in a circuit using Kirchhoff's voltage law

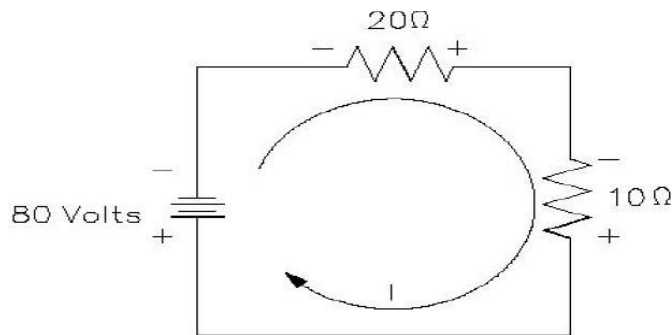

Solution:

$$80 = 20(I) + 10(I)$$

$$80 = 30(I)$$

$$I = 80/30 = 2.66 \text{ amperes}$$

1.5. DC CIRCUITS:

- A DC circuit (Direct Current circuit) is an electrical circuit that consists of any combination of constant voltage sources, constant current sources, and resistors. In this case, the circuit voltages and currents are constant, i.e., independent of time. More technically, a DC circuit has no memory. That is, a particular circuit voltage or current does not depend on the past value of any circuit voltage or current. This implies that the system of equations that represent a DC circuit do not involve integrals or derivatives.
- If a capacitor and/or inductor is added to a DC circuit, the resulting circuit is not, strictly speaking, a DC circuit. However, most such circuits have a DC solution. This solution gives the circuit voltages and currents when the circuit is in DC steady state. More technically, such a circuit is represented by a system of differential equations. The solutions to these equations usually contain a time varying or transient part as well as constant or steady state part. It is this steady state part that is the DC solution. There are some circuits that do not have a DC solution. Two simple examples are a constant current source connected to a capacitor and a constant voltage source connected to an inductor.
- In electronics, it is common to refer to a circuit that is powered by a DC voltage source such as a battery or the output of a DC power supply as a DC circuit even though what is meant is that the circuit is DC powered.

1.6. AC CIRCUITS:

Fundamentals of AC:

- An alternating current (AC) is an electrical current, where the magnitude of the current varies in a cyclical form, as opposed to direct current, where the polarity of the current stays constant.
- The usual waveform of an AC circuit is generally that of a sine wave, as these results in the most efficient transmission of energy. However in certain applications different waveforms are used, such as triangular or square waves.
- Used generically, AC refers to the form in which electricity is delivered to businesses and residences. However, audio and radio signals carried on electrical wire are also examples of alternating current. In these applications, an important goal is often the recovery of information encoded (or modulated) onto the AC signal.

1.7. DIFFERENCE BETWEEN AC AND DC:

Current that flows continuously in one direction is called direct current. Alternating current (A.C) is the current that flows in one direction for a brief time then reverses and flows in opposite direction for a similar time. The source for alternating current is called a.c generator or alternator.

Cycle:

- One complete set of positive and negative values of an alternating quantity is called cycle.

Frequency:

- The number of cycles made by an alternating quantity per second is called frequency. The unit of frequency is Hertz (Hz)

Amplitude or Peak value:

- The maximum positive or negative value of an alternating quantity is called amplitude or peak value.

Average value:

- This is the average of instantaneous values of an alternating quantity over one complete cycle of the wave.

Time period:

- The time taken to complete one complete cycle.

Average value derivation:

Let i = the instantaneous value of current and $i = I_m \sin \theta$

Where, I_m is the maximum value.

Resistors in series and parallel circuits:

Series circuits:

Figure shows three resistors R_1 , R_2 and R_3 connected end to end, i.e. in series, with a battery source of V volts. Since the circuit is closed a current I will flow and the p.d. across each resistor may be determined from the voltmeter readings V_1 , V_2 and V_3

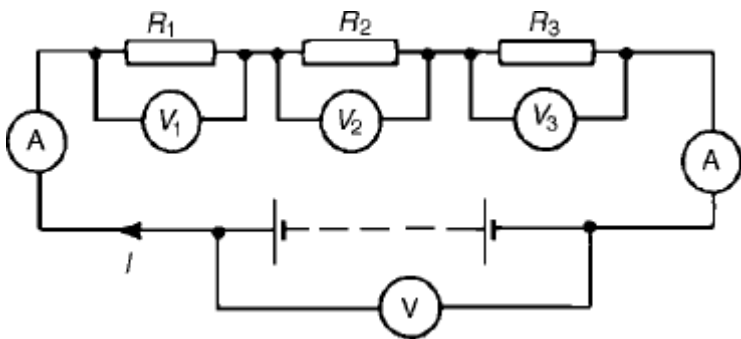

In a series circuit

(a) the current I is the same in all parts of the circuit and hence the same reading is found on each of the two ammeters shown, and

(b) the sum of the voltages V_1 , V_2 and V_3 is equal to the total applied voltage, V , i.e.

$$V = V_1 + V_2 + V_3$$

From Ohm's law:

$$V_1 = IR_1, V_2 = IR_2, V_3 = IR_3 \text{ and } V = IR$$

where R is the total circuit resistance.

$$\text{Since } V = V_1 + V_2 + V_3$$

$$\text{then } IR = IR_1 + IR_2 + IR_3$$

Dividing throughout by I gives

$$R = R_1 + R_2 + R_3$$

Thus for a series circuit, the total resistance is obtained by adding together the values of the separate resistances.

Problem 1: For the circuit shown in Figure 5.2, determine (a) the battery voltage V , (b) the total resistance of the circuit, and (c) the values of resistance of resistors R_1 , R_2 and R_3 , given that the p.d.'s across R_1 , R_2 and R_3 are $5V$, $2V$ and $6V$ respectively.

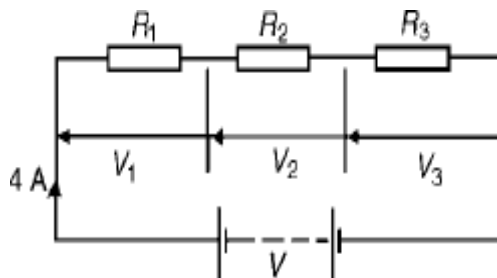

(a) Battery voltage $V = V_1 + V_2 + V_3$

$$= 5 + 2 + 6 = 13V$$

(b) Total circuit resistance $R = V / I$

$$= 13 / 4 = 3.25\Omega$$

(c) Resistance $R_1 = V_1 / I$

$$= 5 / 4$$

$$= 1.25 \Omega$$

Resistance $R_2 = V_2 / I$

$$= 2 / 4$$

$$= 0.5 \Omega$$

Resistance $R_3 = V_3 / I$

$$= 6 / 4$$

$$= 1.5 \Omega$$

Problem 2. For the circuit shown in Figure determine the p.d. across resistor R_3 . If the total resistance of the circuit is 100Ω , determine the current flowing through resistor R_1 . Find also the value of resistor R_2 .

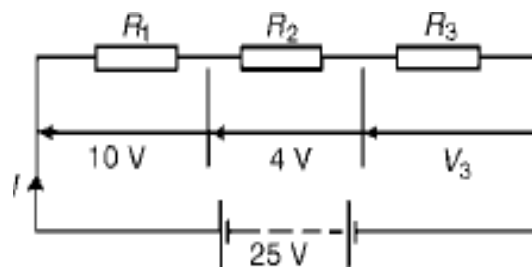

P.d. across R3, $V_3 = 25 - 10 - 4 = 11V$

Current $I = V/R$

$$= 25/100$$

$= 0.25A$, which is the current flowing in each resistor

Resistance $R_2 = V_2/I$

$$= 4/0.25$$

$$= 16 \Omega$$

Problem 3: A 12V battery is connected in a circuit having three series-connected resistors having resistances of 4Ω , 9Ω and 11Ω . Determine the current flowing through, and the p.d. across the 9Ω resistor. Find also the power dissipated in the 11Ω resistor.

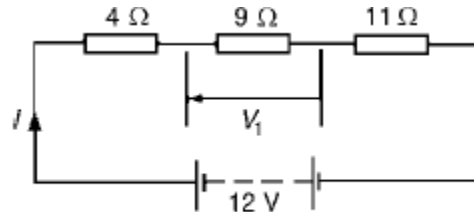

Total resistance $R = 4 + 9 + 11 = 24 \Omega$

Current $I = V/R$

$$= 12/24$$

$= 0.5A$, which is the current in the 9Ω resistor.

P.d. across the 9Ω resistor, $V_1 = I \times 9 = 0.5 \times 9$

$$= 4.5V$$

Power dissipated in the 11Ω resistor, $P = I^2R = 0.5^2(11)$

$$= 0.25(11)$$

$$= 2.75W$$

1.8. PARALLEL NETWORKS:

Problem 1: Figure shows three resistors, R_1 , R_2 and R_3 connected across each other, i.e. in parallel, across a battery source of V volts.

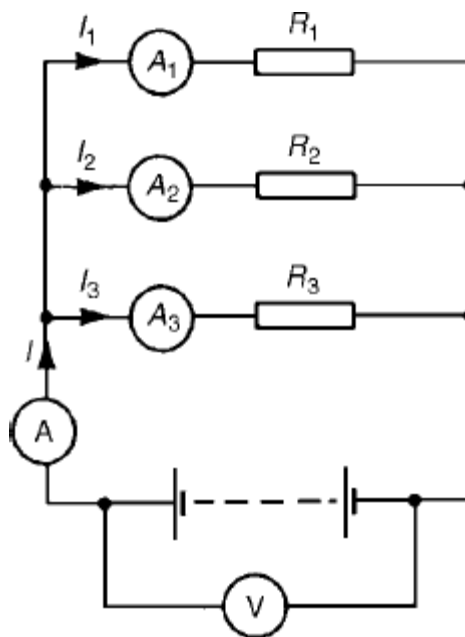

In a parallel circuit:

(a) the sum of the currents I_1 , I_2 and I_3 is equal to the total circuit current, I , i.e. $I = I_1 + I_2 + I_3$, and

(b) the source p.d., V volts, is the same across each of the

resistors.

From Ohm's law:

$$I_1 = V/R_1$$

$$, I_2 = V/R_2$$

$$, I_3 = V/R_3$$

and $I = V/R$

where R is the total circuit resistance.

$$\text{Since } I = I_1 + I_2 + I_3$$

then

$$V/R = V/R_1 + V/R_2 + V/R_3$$

Dividing throughout by V gives:

$$\frac{1}{R} = \frac{1}{R_1} + \frac{1}{R_2} + \frac{1}{R_3}$$

This equation must be used when finding the total resistance R of a parallel circuit. For the special case of two resistors in parallel

$$R = \frac{R_1 R_2}{R_1 + R_2}$$

Problem 2: For the circuit shown in Figure , determine (a) the reading on the ammeter, and (b) the value of resistor R_2 .

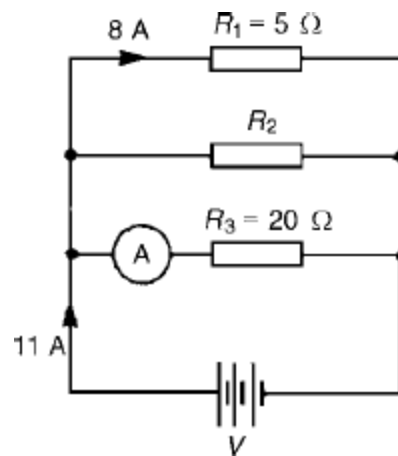

P.d. across R_1 is the same as the supply voltage V .

Hence supply voltage, $V = 8 \times 5 = 40 \text{ V}$

(a) Reading on ammeter, $I = V$

$$R_3 = 40/20 = 2 \text{ A}$$

(b) Current flowing through $R_2 = 11 - 8 - 2 = 1 \text{ A}$

Hence, $R_2 = V/I_2 = 40/1 = 40 \Omega$

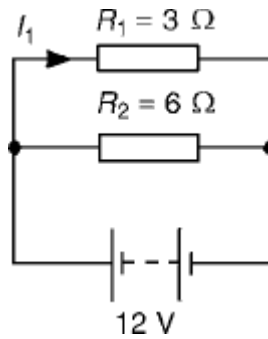

(a) The total circuit resistance R is given by

$$1/R = 1/R_1 + 1/R_2 = 1/3 + 1/6$$

$$1/R = 2 + 1/6 = 3/6$$

$$\text{Hence, } R = 6/3 = 2 \Omega$$

(b) Current in the 3Ω resistance, $I_1 = V$

$$R_1 = 12/3 = 4A$$

Problem 3: For the circuit shown in Figure find (a) the value of the supply voltage V and (b) the value of current I .

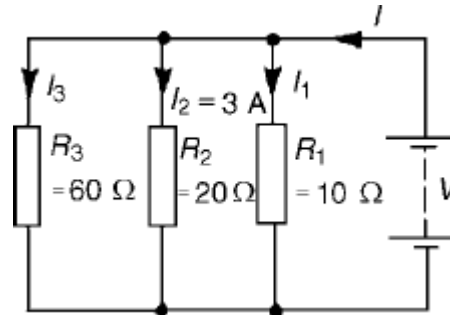

(a) P.d. across 20Ω resistor $= I_2 R_2 = 3 \times 20 = 60V$, hence supply voltage $V = 60V$ since the circuit is connected in parallel.

(b) Current $I_1 = V/R_1 = 60/10 = 6A$; $I_2 = 3A$

$$I_3 = V/R_3 = 60/60 = 1A$$

Current $I = I_1 + I_2 + I_3$ and hence $I = 6 + 3 + 1 = 10A$

Alternatively,

$$1/R = 1/60 + 1/20 + 1/10 = 1 + 3 + 6/60 = 10/60$$

Hence total resistance $R = 60/10 = 6 \Omega$

$$\text{Current } I = V/R = 60/6 = 10A$$

Problem 4: Find the equivalent resistance for the circuit shown in Figure

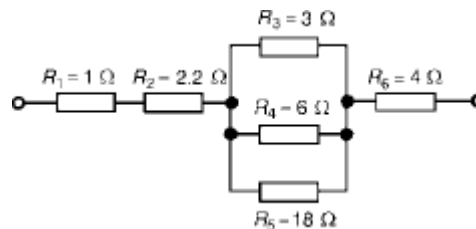

R_3 , R_4 and R_5 are connected in parallel and their equivalent resistance R is given by:

$$1/R = 1/3 + 1/6 + 1/18 = 6 + 3 + 1/18 = 10/18$$

$$\text{Hence } R = 18/10 = 1.8 \Omega$$

The circuit is now equivalent to four resistors in series and the equivalent circuit resistance $= 1 + 2.2 + 1.8 + 4 = 9 \Omega$

1.9. MESH ANALYSIS:

This is an alternative structured approach to solving the circuit and is based on calculating mesh currents. A similar approach to the node situation is used. A set of equations (based on KVL for each mesh) is formed and the equations are solved for unknown values. As many equations are needed as unknown mesh currents exist.

Step 1: Identify the mesh currents

Step 2: Determine which mesh currents are known

Step 2: Write equation for each mesh using KVL and that includes the mesh currents

Step 3: Solve the equations

Step 1:

The mesh currents are as shown in the diagram on the next page

Step 2:

Neither of the mesh currents is known

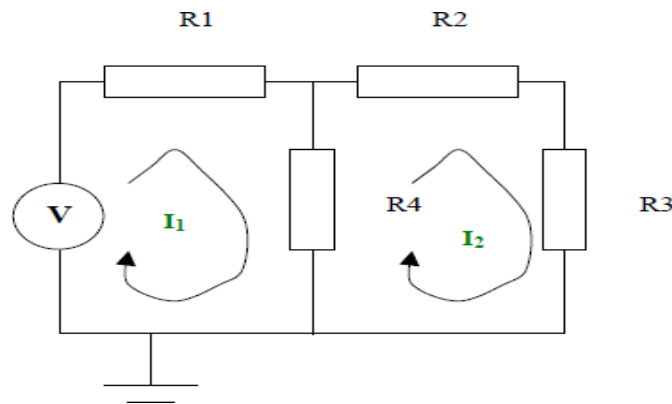

Step 3:

KVL can be applied to the left hand side loop. This states the voltages around the loop sum to zero. When writing down the voltages across each resistor Ohm's law is used. The currents used in the equations are the mesh currents.

$$I_1 R_1 + (I_1 - I_2) R_4 - V = 0$$

KVL can be applied to the right hand side loop. This states the voltages around the loop sum to zero. When writing down the voltages across each resistor Ohm's law is used. The currents used in the equations are the mesh currents.

$$I_2 R_2 + I_2 R_3 + (I_2 - I_1) R_4 = 0$$

Step 4:

Solving the equations we get

$$I_1 = V \frac{R_2 + R_3 + R_4}{R_1 R_2 + R_1 R_3 + R_1 R_4 + R_2 R_4 + R_3 R_4}$$

$$I_2 = V \frac{R_4}{R_1 R_2 + R_1 R_3 + R_1 R_4 + R_2 R_4 + R_3 R_4}$$

The individual branch currents can be obtained from these mesh currents and the node voltages can also be calculated using this information. For example:

$$V_C = I_2 R_3 = V \frac{R_3 R_4}{R_1 R_2 + R_1 R_3 + R_1 R_4 + R_2 R_4 + R_3 R_4}$$

Problem 1:

Use mesh-current analysis to determine the current flowing in (a) the 5Ω resistance, and (b) the 1Ω resistance of the d.c. circuit shown in Figure.

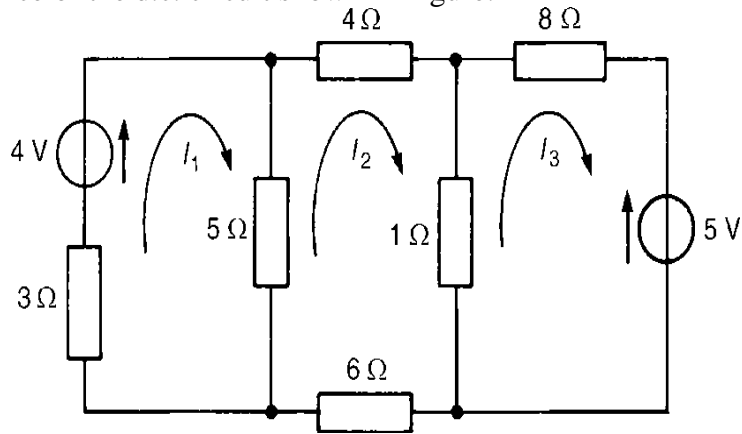

The mesh currents I_1 , I_2 and I_3 are shown in

Figure Using Kirchhoff's voltage law:

For loop 1, $(3 + 5) I_1 - I_2 = 4$ (1)

For loop 2, $(4 + 1 + 6 + 5) I_2 - (5) I_1 - (1) I_3 = 0$ (2)

For loop 3, $(1 + 8) I_3 - (1) I_2 = -5$ (3)

Thus

$$8I_1 - 5I_2 - 4 = 0$$

$$-5I_1 + 16I_2 - I_3 = 0$$

$$-I_2 + 9I_3 + 5 = 0$$

$$\frac{I_1}{-5 \begin{vmatrix} -1 & 0 \\ 9 & 5 \end{vmatrix} - 4 \begin{vmatrix} 16 & -1 \\ -1 & 9 \end{vmatrix}} = \frac{-I_2}{8 \begin{vmatrix} -1 & 0 \\ 9 & 5 \end{vmatrix} - 4 \begin{vmatrix} -5 & -1 \\ 0 & 9 \end{vmatrix}}$$

$$= \frac{I_3}{-4 \begin{vmatrix} -5 & 16 \\ 0 & -1 \end{vmatrix} + 5 \begin{vmatrix} 8 & -5 \\ -5 & 16 \end{vmatrix}}$$

$$= \frac{-1}{8 \begin{vmatrix} 16 & -1 \\ -1 & 9 \end{vmatrix} + 5 \begin{vmatrix} -5 & -1 \\ 0 & 9 \end{vmatrix}}$$

$$\frac{I_1}{-5(-5) - 4(143)} = \frac{-I_2}{8(-5) - 4(-45)}$$

$$= \frac{I_3}{-4(5) + 5(103)}$$

$$= \frac{-1}{8(143) + 5(-45)}$$

$$\frac{I_1}{-547} = \frac{-I_2}{140} = \frac{I_3}{495} = \frac{-1}{919}$$

$$\begin{aligned} \frac{I_1}{\begin{vmatrix} -5 & 0 & -4 \\ 16 & -1 & 0 \\ -1 & 9 & 5 \end{vmatrix}} &= \frac{-I_2}{\begin{vmatrix} 8 & 0 & -4 \\ -5 & -1 & 0 \\ 0 & 9 & 5 \end{vmatrix}} = \frac{I_3}{\begin{vmatrix} 8 & -5 & -4 \\ -5 & 16 & 0 \\ 0 & -1 & 5 \end{vmatrix}} \\ &= \frac{-1}{\begin{vmatrix} 8 & -5 & 0 \\ -5 & 16 & -1 \\ 0 & -1 & 9 \end{vmatrix}} \end{aligned}$$

Using determinants,

$$\text{Hence } I_1 = \frac{547}{919} = 0.595 \text{ A,}$$

$$I_2 = \frac{140}{919} = 0.152 \text{ A, and}$$

$$I_3 = \frac{-495}{919} = -0.539 \text{ A}$$

$$\begin{aligned} \text{(a) Current in the } 5 \Omega \text{ resistance} &= I_1 - I_2 \\ &= 0.595 - 0.152 \\ &= 0.44 \text{ A} \end{aligned}$$

$$\begin{aligned} \text{(b) Current in the } 1 \Omega \text{ resistance} &= I_2 - I_3 \\ &= 0.152 - (-0.539) \\ &= 0.69 \text{ A} \end{aligned}$$

Problem 2: For the a.c. network shown in Figure determine, using mesh-current analysis, (a) the mesh currents I_1 and I_2 (b) the current flowing in the capacitor, and (c) the active power delivered by the $100\angle 0^\circ$ V voltage source.

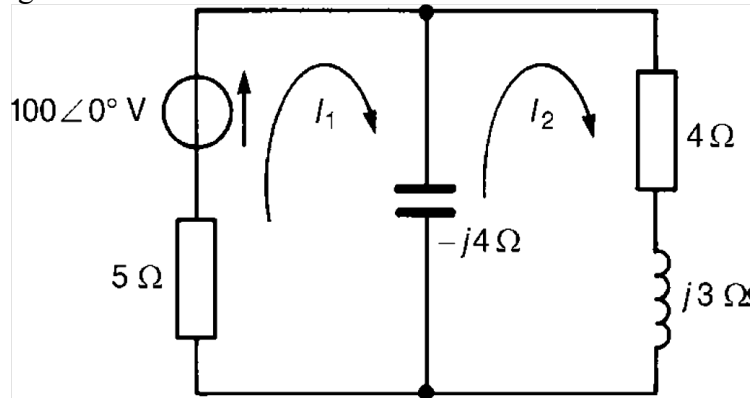

(a) For the first loop
 $(5-j4) I_1 - (-j4I_2) = 100\angle 0^\circ \dots\dots\dots(1)$

For the second loop
 $(4+j3-j4)I_2 - (-j4I_1) = 0 \dots\dots\dots(2)$

Rewriting equations (1) and (2) gives:

$$(5 - j4)I_1 + j4I_2 - 100 = 0$$

$$j4I_1 + (4 - j) I_2 + 0 = 0$$

Thus, using determinants,

(b) Current flowing

$$I_1 - I_2 = \frac{\begin{vmatrix} j4 & -100 \\ (4-j) & 0 \end{vmatrix}}{\begin{vmatrix} (5-j4) & j4 \\ j4 & (4-j) \end{vmatrix}} = \frac{-I_2}{\begin{vmatrix} (5-j4) & j4 \\ j4 & (4-j) \end{vmatrix}}$$

$$= 10.77\angle 19.23^\circ$$

$$= 4.44 + j12$$

i.e. the current

(c) Source power P

$$\frac{I_1}{(400 - j100)} = \frac{-I_2}{j400} = \frac{1}{(32 - j21)}$$

Hence $I_1 = \frac{(400 - j100)}{(32 - j21)} = \frac{412.31\angle -14.04^\circ}{38.28\angle -33.27^\circ}$
 $= 10.77\angle 19.23^\circ \text{ A} = 10.8\angle -19.2^\circ \text{ A},$

(Check: power i correct to one decimal place

anc $I_2 = \frac{400\angle -90^\circ}{38.28\angle -33.27^\circ} = 10.45\angle -56.73^\circ \text{ A}$
 $= 10.5\angle -56.7^\circ \text{ A},$

Thus total power dissipated = $579.97 + 436.81$
 $= 1016.8\text{W} = 1020\text{W}$

Problem 3: Calculate current through 6Ω resistance using loop analysis.(AU-JUNE-12)

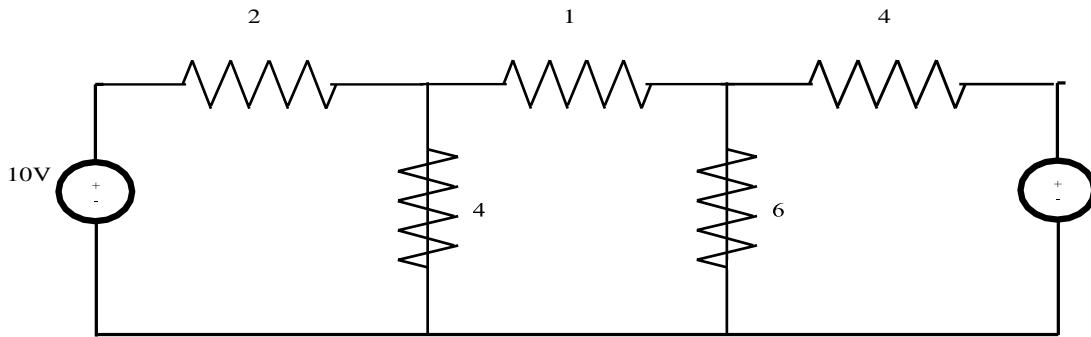

Solution:

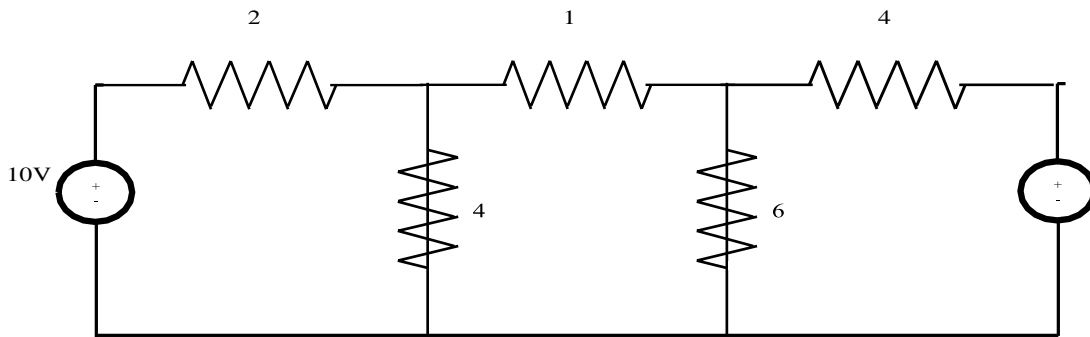

Case(1): Consider loop ABGH ; Apply KVL .

$$10 = 2I_1 + 4(I_1 - I_2)$$

$$10 = 6I_1 - 4I_2 \text{ ----- (1)}$$

Consider loop BCFG

$$I_2 + 6(I_2 + I_3) + 4(I_2 - I_1) = 0$$

$$11I_2 + 6I_3 - 4I_1 = 0 \text{ ----- (2)}$$

Consider loop CDEF

$$20 = 4I_3 + 6(I_2 = I_3)$$

$$20 = 10I_3 + 6I_2 \text{ ----- (3)}$$

$$D = \begin{vmatrix} 6 & -4 & 0 \\ -4 & 11 & 6 \\ 0 & 6 & 10 \end{vmatrix}$$

$$= \begin{vmatrix} 10 \\ 0 \\ 20 \end{vmatrix}$$

$$D = [6(110 - 36) + 4(-40)] = 284.$$

$$D_1 = \begin{vmatrix} 10 & -4 & 0 \\ 0 & 11 & 6 \\ 20 & 6 & 10 \end{vmatrix}$$

$$D_1 = 10[110 - 36 + (-120)]$$

$$= 260$$

$$D_2 = \begin{vmatrix} 6 & 10 & 0 \\ -4 & 0 & 6 \\ 0 & 20 & 10 \end{vmatrix}$$

$$D_2 = 6(-120) - 10(-40) = -320$$

$$D_3 = \begin{vmatrix} 6 & -4 & 10 \\ -4 & 11 & 0 \\ 0 & 6 & 20 \end{vmatrix}$$

$$D_3 = 6(220) + 4(-80) + 10(-24)$$

$$D_3 = 760$$

$$I_1 = D_1/D = 260/284 = 0.915A$$

$$I_2 = D_2/D = -320/284 = -1.1267A$$

$$I_3 = D_3/D = 760/284 = 2.676A$$

$$\text{Current through } 6\Omega \text{ resistance} = I_2 + I_3$$

$$= -1.1267 + 2.676 = 1.55A$$

Problem 4: Find the current through branch a-b using mesh analysis. (JUN-09)

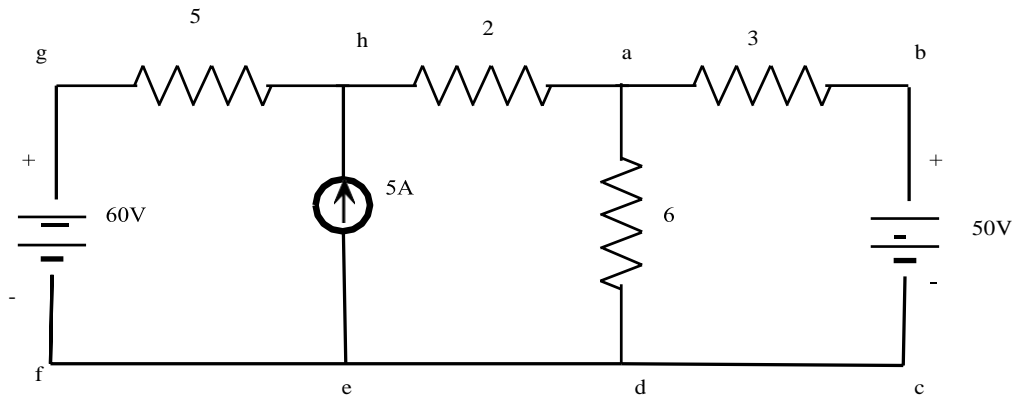
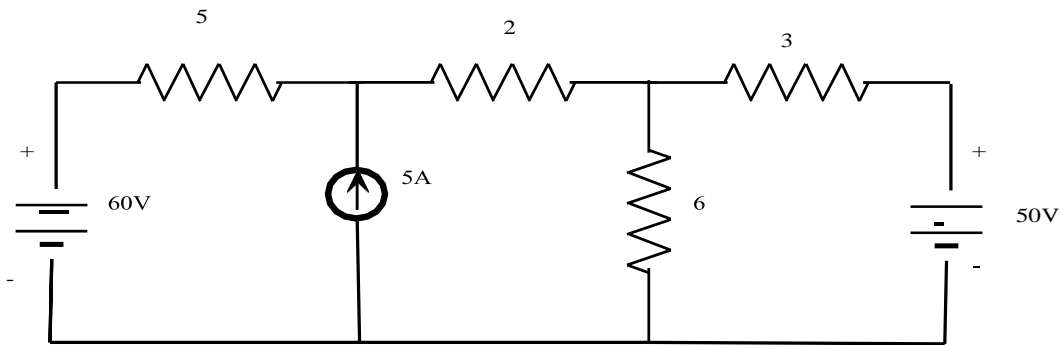

Solution:

Consider loops

$$\text{Loop HADE} \rightarrow 5I_1 + 2I_2 + 6(I_2 - I_3) = 60$$

$$5I_1 + 8I_2 - 6I_3 = 60 \text{ ----- (1)}$$

$$\text{Loop ABCDA} \rightarrow 3I_3 + 6(I_3 - I_2) = -50$$

$$3I_3 + 6I_3 - 6I_2 = -50$$

$$9I_3 - 6I_2 = -50 \text{ ----- (2)}$$

$$I_2 - I_1 = 5A \text{ ----- (3)}$$

From (1), (2) & (3).

$$D = \begin{vmatrix} -1 & 1 & 0 \\ 5 & 8 & -6 \\ 0 & -6 & 9 \end{vmatrix}$$

$$\begin{aligned}
 &= -1(72-36)-1(45) \\
 D &= -81. \\
 D_3 &= \begin{vmatrix} -1 & 1 & 5 \\ 5 & 8 & 60 \\ 0 & -6 & -50 \end{vmatrix} \\
 &= -1(-400+360)-(-250) +5(-30) \\
 &= 40+250-150 \\
 D_3 &= 140. \\
 I_3 &= D_3/D = 140/-81 = -1.7283
 \end{aligned}$$

The current through branch ab is 1.7283A which is flowing from b to a.

1.10. NODAL ANALYSIS:

Nodal analysis involves looking at a circuit and determining all the node voltages in the circuit. The voltage at any given node of a circuit is the voltage drop between that node and a reference node (usually ground). Once the node voltages are known any of the currents flowing in the circuit can be determined. The node method offers an organized way of achieving this.

Approach:

Firstly all the nodes in the circuit are counted and identified. Secondly nodes at which the voltage is already known are listed. A set of equations based on the node voltages are formed and these equations are solved for unknown quantities. The set of equations are formed using KCL at each node. The set of simultaneous equations that is produced is then solved. Branch currents can then be found once the node voltages are known. This can be reduced to a series of steps:

Step 1: Identify the nodes

Step 2: Choose a reference node

Step 3: Identify which node voltages are known if any

Step 4: Identify the BRANCH currents

Step 5: Use KCL to write an equation for each unknown node voltage

Step 6: Solve the equations

This is best illustrated with an example. Find all currents and voltages in the following circuit using the node method. (In this particular case it can be solved in other ways as well)

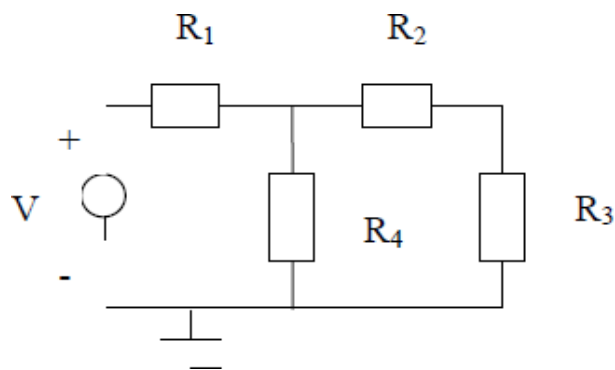

Step 1:

There are four nodes in the circuit. A, B, C and D

Step 2:

Ground, node D is the reference node.

Step 3:

Node voltage B and C are unknown. Voltage at A is V and at D is 0

Step 4:

The currents are as shown. There are 3 different currents

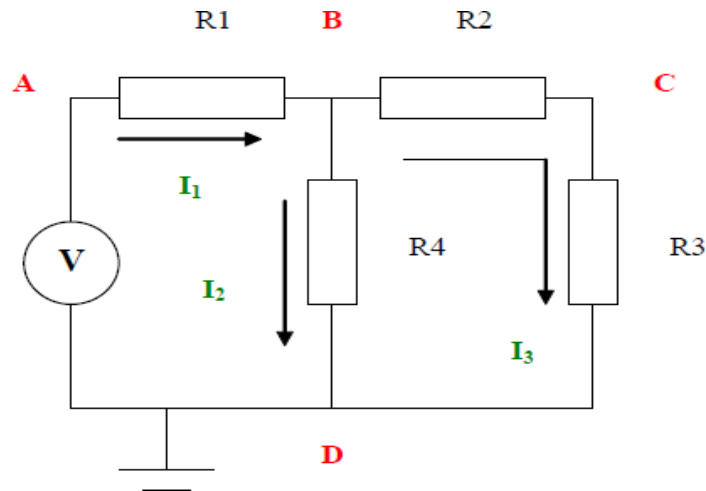

Step 5:

I need to create two equations so I apply KCL at node B and node C
 The statement of KCL for node B is as follows:

$$\frac{V - V_B}{R_1} + \frac{V_C - V_B}{R_2} + \frac{-V_B}{R_4} = 0$$

The statement of KCL for node C is as follows:

$$\frac{V_C - V_B}{R_2} + \frac{-V_C}{R_3} = 0$$

Step 6:

We now have two equations to solve for the two unknowns V_B and V_C . Solving the above two equations we get:

$$V_C = V \frac{R_3 R_4}{R_1 R_2 + R_1 R_3 + R_1 R_4 + R_2 R_4 + R_3 R_4}$$

$$V_B = V \frac{R_4 (R_2 + R_3)}{R_1 R_2 + R_1 R_3 + R_1 R_4 + R_2 R_4 + R_3 R_4}$$

Further Calculations

The node voltages are now all known. From these we can get the branch currents by a simple application of Ohm's Law:

$$I_1 = (V - V_B) / R_1$$

$$I_2 = (V_B - V_C) / R_2$$

$$I_3 = (V_C) / R_3$$

$$I_4 = (V_B) / R_4$$

Problem 1: Find the current through each resistor of the circuit shown in fig, using nodal analysis

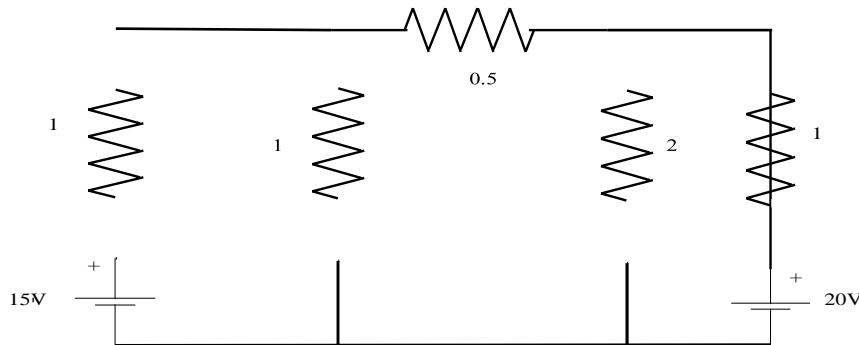

Solution:

At node1,

$$\begin{aligned} -I_1 - I_2 - I_3 &= 0 \\ -[V_1 - 15/1] - [V_1/1] - [V_1 - V_2/0.5] &= 0 \\ -V_1 + 15 - V_1 - 2V_1 + 2V_2 &= 0 \\ 4V_1 - 2V_2 &= 15 \dots\dots\dots(1) \end{aligned}$$

At node2,

$$\begin{aligned} I_3 - I_4 - I_5 &= 0 \\ V_1 - V_2/0.5 - V_2/2 - V_2 - 20/1 &= 0 \\ 2V_1 - 2V_2 - 0.5V_2 - V_2 + 20 &= 0 \\ 2V_1 - 3.5V_2 &= -20 \dots\dots\dots(2) \end{aligned}$$

Multiplying (2) by 2 & subtracting from (1)

$$\begin{aligned} 5V_2 &= 55 \\ V_2 &= 11V \\ V &= 9.25V \end{aligned}$$

$$I_1 = V_1 - 15/1 = 9.25 - 15 = -5.75A = 5.75A$$

$$I_2 = V_1/1 = 9.25A$$

$$I_3 = V_1 - V_2/0.5 = -3.5A = 3.5A \leftarrow$$

$$I_4 = V_2/2 = 5.5A$$

$$I_5 = V_2 - 20/1 = 11 - 20/1 = -9A = 9A.$$

Problem 2: For the bridge network shown in Figure determine the currents in each of the resistors. (DEC-07)

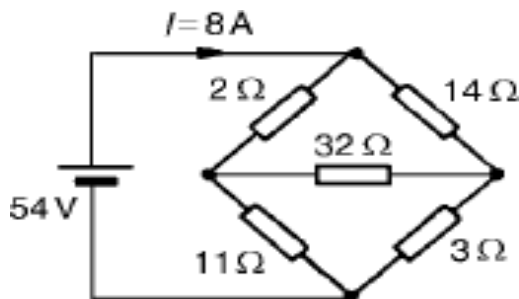

Let the current in the 2 resistor be I_1 , and then by Kirchoff's current law, the current in the 14 resistor is $(I - I_1)$. Let the current in the 32 resistor be I_2 as shown in Figure Then the current in the 11 resistor is $(I_1 - I_2)$ and that in the 3 resistor is $(I - I_1 + I_2)$. Applying Kirchoff's voltage law to loop 1 and moving in a clockwise direction as shown in Figure gives:

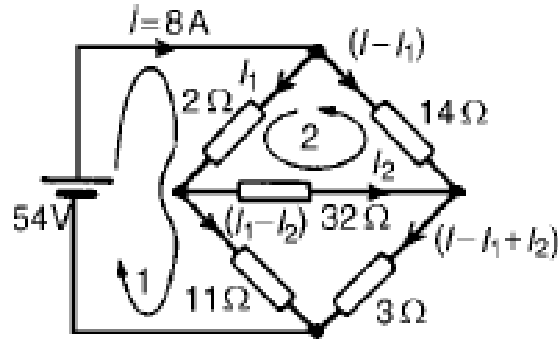

$$54 = 2I_1 + 11(I_1 - I_2)$$

i.e. $13I_1 - 11I_2 = 54$

Applying Kirchoff's voltage law to loop 2 and moving in an anticlockwise direction as shown in Figure gives:

$$0 = 2I_1 + 32I_2 - 14(I - I_1)$$

However $I = 8 \text{ A}$

Hence $0 = 2I_1 + 32I_2 - 14(8 - I_1)$

i.e. $16I_1 + 32I_2 = 112$

Equations (1) and (2) are simultaneous equations with two unknowns, I_1 and I_2 .

$16 * (1)$ gives: $208I_1 - 176I_2 = 864$

$13 * (2)$ gives: $208I_1 + 416I_2 = 1456$

$(4) - (3)$ gives: $592I_2 = 592, I_2 = 1 \text{ A}$

Substituting for I_2 in (1) gives:

$$13I_1 - 11 = 54$$

$$I_1 = 65/13 = 5 \text{ A}$$

Hence,

the current flowing in the 2 resistor = $I_1 = 5 \text{ A}$

the current flowing in the 14 resistor = $I - I_1 = 8 - 5 = 3 \text{ A}$

the current flowing in the 32 resistor = $I_2 = 1 \text{ A}$

the current flowing in the 11 resistor = $I_1 - I_2 = 5 - 1 = 4 \text{ A}$ and

the current flowing in the 3 resistor = $I - I_1 + I_2 = 8 - 5 + 1 = 4 \text{ A}$

Problem 3: Determine the values of currents I , I_1 and I_2 shown in the network of Figure

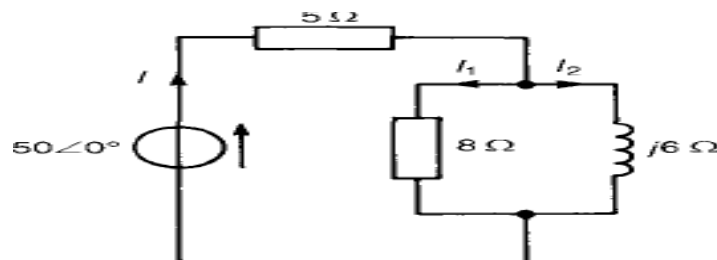

Total circuit impedance,

$$\begin{aligned} Z_T &= 5 + (8)(j6)/8 + j6 \\ &= 5 + (j48)(8 - j6)/8^2 + 6^2 \\ &= 5 + (j384 + 288)/100 \\ &= (7.88 + j3.84) \text{ or } 8.776 \angle 25.98^\circ \text{ A} \end{aligned}$$

Current $I = V/Z_T$

$$\begin{aligned} &= 50 \angle 0^\circ / 8.77 \angle 25.98^\circ \\ &= 5.7066 \angle -25.98^\circ \text{ A} \end{aligned}$$

Current $I_1 = I(j6/8 + j6)$

$$\begin{aligned} &= (5.702 \angle -25.98^\circ) (6 \angle 90^\circ) / 10 \angle 36.87^\circ \\ &= 3.426 \angle 27.15^\circ \text{ A} \end{aligned}$$

Current $I_2 = I(8/(8 + j6))$

$$\begin{aligned} &= (5.70 \angle -25.98^\circ) * 8 \angle 0^\circ / 10 \angle 36.87^\circ \\ &= 4.5666 \angle -62.85^\circ \text{ A} \end{aligned}$$

[Note: $I = I_1 + I_2 = 3.42 \angle 27.15^\circ + 4.56 \angle -62.85^\circ$

$$= 3.043 + j1.561 + 2.081 - j4.058$$

$$= 5.124 - j2.497 \text{ A} = 5.706 \angle -25.98^\circ \text{ A}$$

Problem 4: For the a.c. network shown in Figure, determine the current flowing in each branch using Kirchoff's laws.

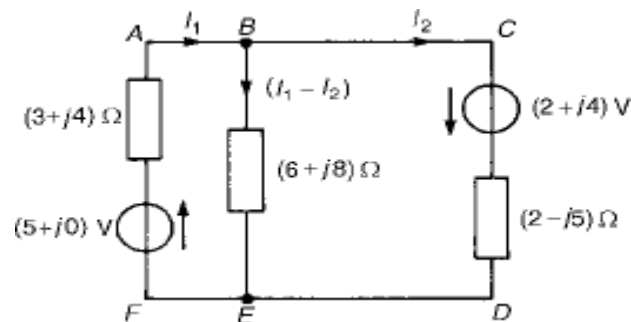
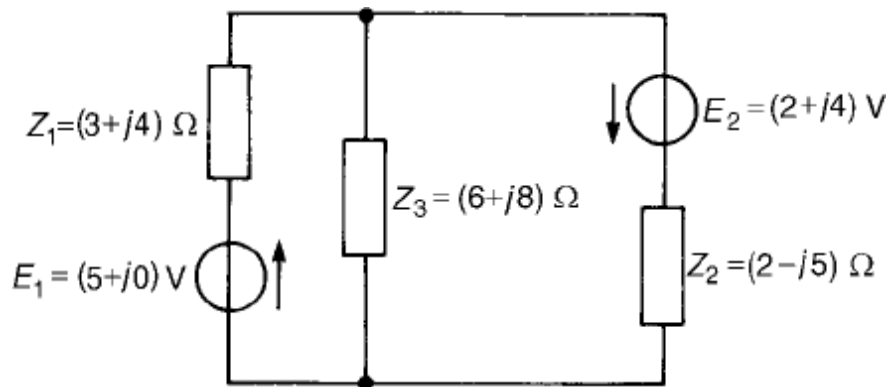

$$\begin{aligned} \text{from which, } I_1 &= \frac{20 + j55}{64 + j27} = \frac{58.52\angle 70.02^\circ}{69.46\angle 22.87^\circ} = \mathbf{0.842\angle 47.15^\circ \text{ A}} \\ &= (0.573 + j0.617) \text{ A} \\ &= \mathbf{(0.57 + j0.62) \text{ A}}, \text{ correct to two decimal places.} \end{aligned}$$

$$\begin{aligned} \text{From equation (1), } 5 &= (9 + j12)(0.573 + j0.617) - (6 + j8)I_2 \\ 5 &= (-2.247 + j12.429) - (6 + j8)I_2 \end{aligned}$$

$$\begin{aligned} \text{from which, } I_2 &= \frac{-2.247 + j12.429 - 5}{6 + j8} \\ &= \frac{14.39\angle 120.25^\circ}{10\angle 53.13^\circ} \\ &= \mathbf{1.439\angle 67.12^\circ \text{ A}} = (0.559 + j1.326) \text{ A} \\ &= \mathbf{(0.56 + j1.33) \text{ A}}, \text{ correct to two decimal places.} \end{aligned}$$

The current in the $(6 + j8)\Omega$ impedance,

$$\begin{aligned} I_1 - I_2 &= (0.573 + j0.617) - (0.559 + j1.326) \\ &= \mathbf{(0.014 - j0.709) \text{ A}} \text{ or } \mathbf{0.709\angle -88.87^\circ \text{ A}} \end{aligned}$$

An alternative method of solving equations (1) and (2) is shown below, using determinants.

$$(9 + j12)I_1 - (6 + j8)I_2 - 5 = 0 \quad (1)$$

$$-(6 + j8)I_1 + (8 + j3)I_2 - (2 + j4) = 0 \quad (2)$$

$$\begin{aligned} \text{Thus } \frac{I_1}{\begin{vmatrix} -(6 + j8) & -5 \\ (8 + j3) & -(2 + j4) \end{vmatrix}} &= \frac{-I_2}{\begin{vmatrix} (9 + j12) & -5 \\ -(6 + j8) & -(2 + j4) \end{vmatrix}} \\ &= \frac{1}{\begin{vmatrix} (9 + j12) & -(6 + j8) \\ -(6 + j8) & (8 + j3) \end{vmatrix}} \\ \frac{I_1}{(-20 + j40) + (40 + j15)} &= \frac{-I_2}{(30 - j60) - (30 + j40)} \\ &= \frac{1}{(36 + j123) - (-28 + j96)} \\ \frac{I_1}{20 + j55} &= \frac{-I_2}{-j100} = \frac{1}{64 + j27} \end{aligned}$$

$$\begin{aligned} \text{Hence } I_1 &= \frac{20 + j55}{64 + j27} = \frac{58.52\angle 70.02^\circ}{69.46\angle 22.87^\circ} \\ &= \mathbf{0.842\angle 47.15^\circ \text{ A}} \end{aligned}$$

and
$$I_2 = \frac{100\angle 90^\circ}{69.46\angle 22.87^\circ} = 1.440\angle 67.13^\circ \text{ A}$$

The current flowing in the $(6 + j8) \Omega$ impedance is given by:

$$\begin{aligned} I_1 - I_2 &= 0.842\angle 47.15^\circ - 1.440\angle 67.13^\circ \text{ A} \\ &= (0.013 - j0.709) \text{ A or } 0.709\angle -88.95^\circ \text{ A} \end{aligned}$$

Problem 5: For the a.c. network shown in Figure determine, using mesh-current analysis, (a) the mesh currents I_1 and I_2 (b) the current flowing in the capacitor, and (c) the active power delivered by the $100\angle 0^\circ \text{ V}$ voltage source.

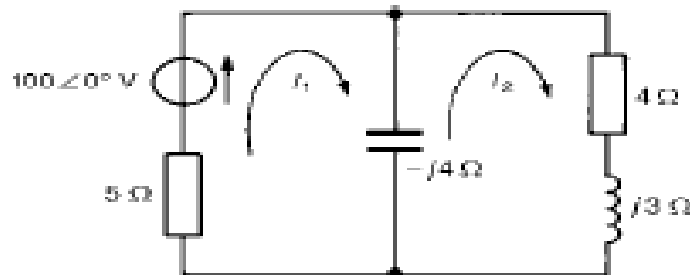

(a) For the first loop $(5 - j4)I_1 - (-j4I_2) = 100\angle 0^\circ$ (1)

For the second loop $(4 + j3 - j4)I_2 - (-j4I_1) = 0$ (2)

Rewriting equations (1) and (2) gives:

$$(5 - j4)I_1 + j4I_2 - 100 = 0 \quad (1')$$

$$j4I_1 + (4 - j)I_2 + 0 = 0 \quad (2')$$

Thus, using determinants,

$$\frac{I_1}{\begin{vmatrix} j4 & -100 \\ (4 - j) & 0 \end{vmatrix}} = \frac{-I_2}{\begin{vmatrix} (5 - j4) & -100 \\ j4 & 0 \end{vmatrix}} = \frac{1}{\begin{vmatrix} (5 - j4) & j4 \\ j4 & (4 - j) \end{vmatrix}}$$

$$\frac{I_1}{(400 - j100)} = \frac{-I_2}{j400} = \frac{1}{(32 - j21)}$$

Hence
$$I_1 = \frac{(400 - j100)}{(32 - j21)} = \frac{412.31\angle -14.04^\circ}{38.28\angle -33.27^\circ}$$

$$= 10.77\angle 19.23^\circ \text{ A} = 10.8\angle -19.2^\circ \text{ A},$$

correct to one decimal place

$$I_2 = \frac{400\angle -90^\circ}{38.28\angle -33.27^\circ} = 10.45\angle -56.73^\circ \text{ A}$$

$$= 10.5\angle -56.7^\circ \text{ A},$$

correct to one decimal place

(c) Source power $P = VI \cos \phi = (100)(10.77) \cos 19.23^\circ$
 $= 1016.9 \text{ W} = 1020 \text{ W}$,
correct to three significant figures.

(Check: power in 5Ω resistor $= I_1^2(5) = (10.77)^2(5) = 579.97 \text{ W}$
and power in 4Ω resistor $= I_2^2(4) = (10.45)^2(4) = 436.81 \text{ W}$

Thus total power dissipated $= 579.97 + 436.81$
 $= 1016.8 \text{ W} = 1020 \text{ W}$, correct
to three significant figures.)

2. Define current. (AU-APR08)

Movement of electrons is called current. It is also defined as flow of charges.

$$\text{Current } I = \frac{dQ}{dt} = \frac{Q}{t}$$

Movement of electrons always flow from negative to positive.

Unit of current is Ampere.

Current is defined as the rate of flow of charge in an electric circuit or in any medium in

(b) Current flowing in capacitor $= I_1 - I_2$
 $= 10.77 \angle 19.23^\circ - 10.45 \angle -56.73^\circ$
 $= 4.44 + j12.28 = 13.1 \angle 70.12^\circ \text{ A}$,

i.e., the current in the capacitor is 13.1 A

which charges are subjected to electric field.

$$I = \frac{Q}{t} \text{ amperes.}$$

DC current: The current does not vary with time is called direct current. It is denoted by I.

AC current: The current varies with time is called alternating current. It is denoted by i (or) i(t).

3. Define potential difference. (AU-APR08)

It is also called as voltage (or) electric potential.

It is defined as the energy required moving the unit of charge from one point to other.

It is also defined as the difference of electric potential between the two points of the conductor.

$$\text{Electric potential} = \frac{\text{workdone}}{\text{charge}} = \frac{W}{Q} = \frac{dW}{dQ}$$

$$\text{Unit of voltage is volt (or) } \frac{\text{J}}{\text{C}}$$

It is denoted by letter V.

4. Define Power and Energy?(AU-APR08)(AU-DEC-10)

The rate of doing work is called power.

Power $P=VI$

$$P = \frac{dW}{dQ} \times \frac{dQ}{dt} = \frac{dW}{dt}$$

Unit of power is Watts (or) $\frac{J}{S}$. It is denoted by letter P.

The rate of doing work with time is called power. It is also called as the capacity to do the work.

Unit of Energy is Watt-hour (or) **Joules**. It is denoted by letter E (or) W.

5. What is electric circuit or electric network?

The combination of various electrical elements such as resistors, capacitors and inductors along with various energy sources such as voltage and current sources is called electric circuit or electric network.

6. Define Independent source.

It is defined as the source voltage independent of current flowing through it and source current independent of voltage across it. It is indicated by circle with polarity of voltage and direction of current. It is also called as uncontrolled sources.

Types of independent of sources.

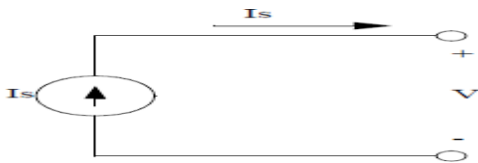

i) Current source

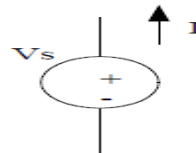

(ii) Voltage source

7. Define Dependent sources. (AU-MAY08)

It is defined as the voltage source or current source depends on voltage or current elsewhere in the given circuit. It is indicated by diamond shape. It is also called as controlled sources.

Types of Dependent of sources.

- (i) Voltage controlled voltage source (VCVS).
- (ii) Voltage controlled current source (VCCS).
- (iii) Current controlled current source (CCCS).
- (iv) Current controlled voltage source (CCVS).

8. Define ideal voltage source

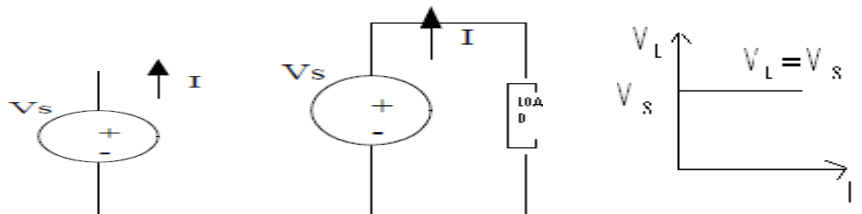

The energy source which gives constant voltage across its terminals irrespective of the current flowing through its terminal is called ideal voltage source. At any time the value of voltage at load terminals remains same.

9. Define practical voltage source.

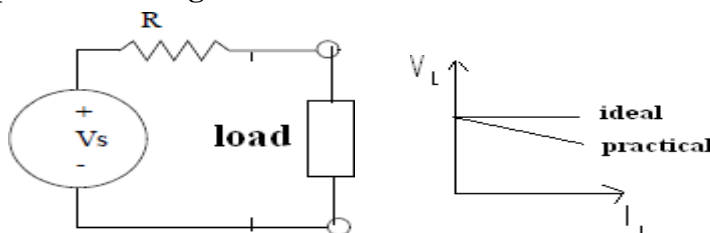

Practical voltage source has small amount of resistance (R_{se}) in series with voltage source.

$$V_L = V_s - I_L R_{se}$$

Due to R_{se} , the voltage across load terminals decreases slightly with increase in current.

10. Define time invariant voltage source. (AU-MAY08)

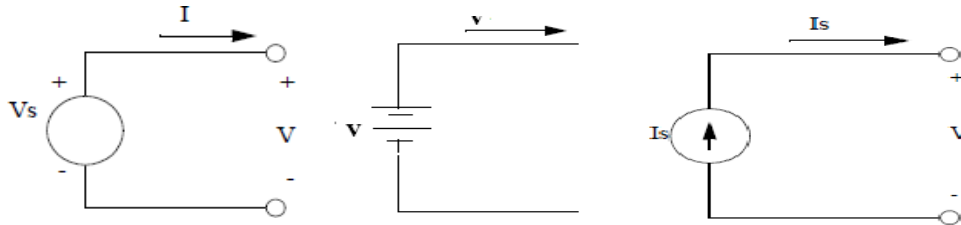

The source in which voltage or current is not varying with time is called time invariant sources. It is also called as DC sources. It is denoted by capital letters.

11. Define time variant voltage source. (AU-MAY08)

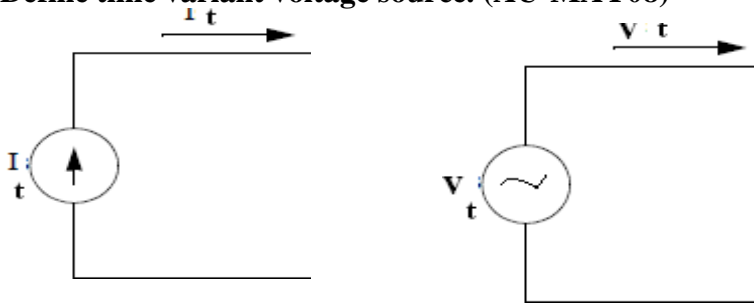

The source in which voltage or current is varying with time is called time variant sources. It is also called as AC sources. It is denoted by small letters.

12. Define resistance.



The property of opposition of flow of current is called resistance.

Unit of resistance: ohm

It is denoted by letter R.

Power dissipated in resistor $P=I^2R$

13. Define inductance.

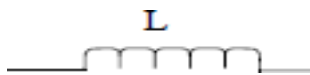

The property of opposition of flow of change in current is called inductance.

Unit of resistance: Henry

It is denoted by letter L.

Energy stored in the inductor $E= \frac{Li^2}{2}$

It stores the energy in the form of magnetic field.

14. Define capacitance.

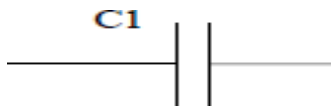

The property of opposition of flow of change in voltage is called capacitance.

Unit of resistance: Farad

It is denoted by letter C.

Energy stored in the inductor $E = \frac{CV^2}{2}$

It stores the energy in the form of electrostatic field.

15. Define branch and node.

Branch: It is a portion of a circuit with two terminal connected to it. A branch may contain one or more elements.

Node: It is a junction of two or more branches.

16. Define mesh or loop.

It is defined as a set of branches forming a closed path in a network.

17. Define active and passive elements.(DEC-10)

Active element: Active elements are the elements which supply power or energy to the network.

Ex. Voltage source, current source

Passive element: Passive elements are the elements which either store energy or dissipate energy in the form of heat.

Ex. Capacitor and inductor=store the energy

Resistor=dissipate the energy

18. Define lumped and distributed network. (AU-MAY08)

Lumped network: A network consisting of physically separable elements such as resistor, capacitor and inductor is known as lumped network.

Ex. RLC network

Distributed network: A network consisting of elements that are not separable for analytical purpose is known as distributed network.

Ex. Transmission lines(R, L ad C is distributed along its length)

19. Define bilateral and unilateral network. (DEC-07)

Bilateral network: The voltage-currant relationship is same for current flowing in either direction is called bilateral network.

Ex. R, L and C

Unilateral network: The network has different relationships between voltage and current for the two possible directions of current.

Ex: Diodes, vaccum tubes

20. Define linear and non-linear network. (DEC-07)

Linear network: The relationship between voltage and current is linear, then the network is called linear network.

Ex:Resistance

Non-Linear network: The networks which do not satisfy the linear voltage-current relationship is called non-linear network.

Ex: Diodes, Zener Diodes

21. State Ohm's law.

At constant temperature. the current flowing through the resistor is directly proportional to voltage across the resistor.

$$V \propto I, V=IR$$

$$R = \frac{V}{I} = \text{constant}$$

Power dissipated in resistor $P=I^2R = VI = \frac{V^2}{R}$

22. Write the limitations of ohm's law.(DEC-10)

(i) It is not applicable to non-linear devices such as diodes, zener diodes and voltage regulators.

(ii) It is not applicable for non metallic conductors. Ex. silicon carbide

(iii) It is not applicable for arc lamps, electronic valves and electrolytes.

23. State Kirchoff's current law. (JUN-09) (DEC-07)(JUN-10)

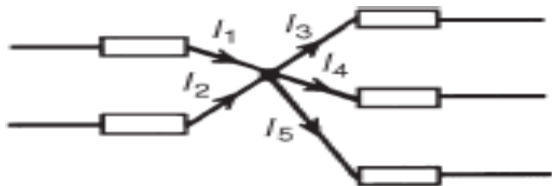

$$I_1 + I_2 = I_3 + I_4 + I_5 \quad \text{or} \quad I_1 + I_2 - I_3 - I_4 - I_5 = 0$$

It is also called as point law (or) Kirchoff's first law.

It is defined as algebraic sum of currents meeting at any node is equal to zero.

(Or)

At any node, sum of incoming current is equal to sum of outgoing current

Sign convention:

Positive: current flowing towards junction.

Negative: current flowing away from junction.

24. State Kirchoff's voltage law. (JUN-09) (DEC-07)(DEC-10)(JUN-10)

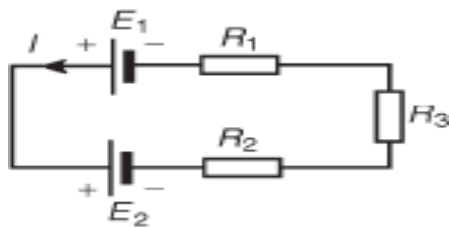

$$E_1 - E_2 = IR_1 + IR_2 + IR_3$$

It is also called as mesh law (or) loop law (or) Kirchoff's second law.

It is defined as algebraic sum of voltages around any closed path is equal to zero.

At any closed path, sum of voltage rise is equal to sum of voltage drop

Sign convention:

Voltage rise: current flowing from -ve to +ve terminal of battery. It must be taken as positive.

Voltage drop: current flowing from +ve to -ve terminal of battery. It must be taken as negative.

25. Write the characteristics of series connection of resistances.

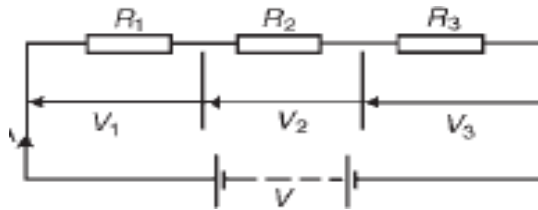

(i) Same current flows through each resistance.

(ii) Supply voltage V is the sum of individual voltage drops across each resistance.

$$V = V_1 + V_2 + V_3$$

(iii) Equivalent resistance is equal to sum of individual resistance.

$$R_{eq} = R_1 + R_2 + R_3$$

(iv) Equivalent resistance is the largest of all individual resistance.

>

$$R_{eq} R_1, R_2, R_3$$

Ex. Decoration lamps.

UNIT II

NETWORK REDUCTION AND NETWORK THEOREMS FOR DC AND AC CIRCUITS

Network reduction: voltage and current division, source transformation – star delta conversion.

Thevenin's and Norton's Theorem – Superposition Theorem – Maximum power transfer theorem – Reciprocity Theorem.

2.1. NETWORK REDUCTION:

2.2. VOLTAGE AND CURRENT DIVISION:

2.3. POTENTIAL DIVIDER:

The voltage distribution for the circuit shown in Figure

$$V_1 = \left(\frac{R_2}{R_1 + R_2} \right) V$$

$$V_2 = \left(\frac{R_1}{R_1 + R_2} \right) V$$

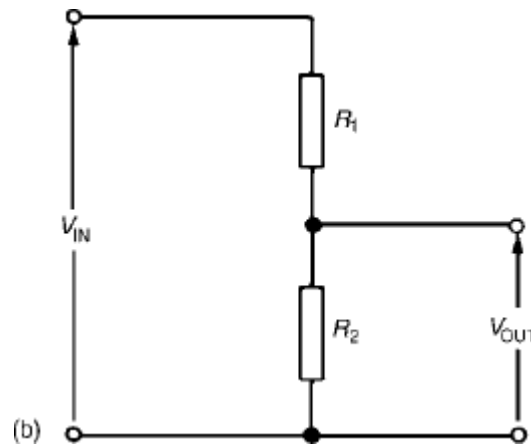
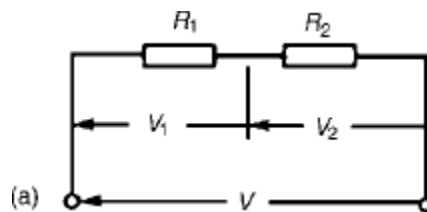

The circuit shown in Figure (b) is often referred to as a potential divider circuit. Such a circuit can consist of a number of similar elements in series connected across a voltage source, voltages being taken from connections between the elements. Frequently the divider consists of two resistors as shown in Figure (b), where

$$V_{OUT} = \left(\frac{R_2}{R_1 + R_2} \right) V_{IN}$$

A potential divider is the simplest way of producing a source of lower e.m.f. from a source of

higher e.m.f., and is the basic operating mechanism of the potentiometer, a measuring device for accurately measuring potential differences

Problem 1: Determine the value of voltage V

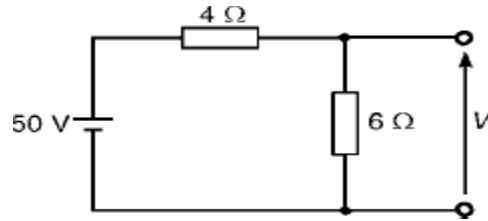

$$V = \left(\frac{6}{6 + 4} \right) (50) = 30 \text{ V}$$

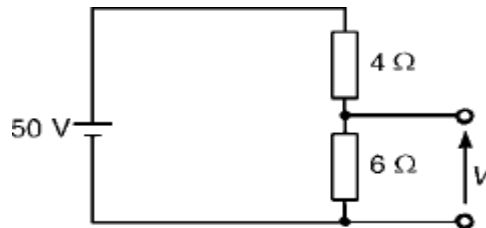

Problem 2: Two resistors are connected in series across a 24V supply and a current of 3A flows in the circuit. If one of the resistors has resistances of 2Ω determine (a) the value of the other resistor, and (b) the p.d. across the 2Ω resistor. If the circuit is connected for 50 hours, how much energy is used?

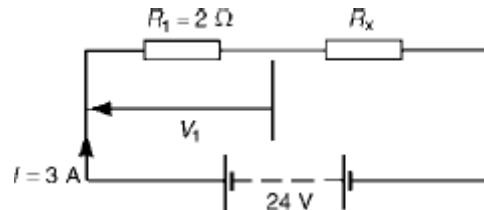

(a) Total circuit resistance $R = V / I$

$$= 24 / 3 = 8 \Omega$$

Value of unknown resistance, $R_x = 8 - 2 = 6 \Omega$

(b) P.d. across 2Ω resistor, $V_1 = IR_1 = 3 \times 2 = 6 \text{ V}$

Alternatively, from above,

$$V_1 = (R_1 / (R_1 + R_x)) V = (2 / (2 + 6)) (24) = 6 \text{ V}$$

Energy used = power \times time

$$= V \times I \times t$$

$$= (24 \times 3 \text{ W}) (50 \text{ h})$$

$$= 3600 \text{ Wh} = 3.6 \text{ kWh}$$

Current division:

For the circuit shown in Figure, the total circuit resistance, R_T is given by:

$$R_T = R_1 R_2 / (R_1 + R_2)$$

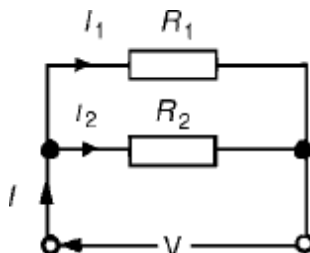

$$\text{and } V = IR_T = I \left(\frac{R_1 R_2}{R_1 + R_2} \right)$$

$$\text{Current } I_1 = \frac{V}{R_1} = \frac{I}{R_1} \left(\frac{R_1 R_2}{R_1 + R_2} \right) = \left(\frac{R_2}{R_1 + R_2} \right) (I)$$

Similarly,

$$\text{current } I_2 = \frac{V}{R_2} = \frac{I}{R_2} \left(\frac{R_1 R_2}{R_1 + R_2} \right) = \left(\frac{R_1}{R_1 + R_2} \right) (I)$$

Summarizing, with reference to Figure 5.20

$$I_1 = \left(\frac{R_2}{R_1 + R_2} \right) (I) \quad \text{and} \quad I_2 = \left(\frac{R_1}{R_1 + R_2} \right) (I)$$

Problem 1: For the series-parallel arrangement shown in Figure, find (a) the supply current, (b) the current flowing through each resistor and (c) the p.d. across each resistor.

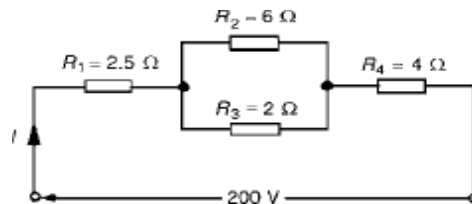

(a) The equivalent resistance R_x of R_2 and R_3 in parallel is:

$$\begin{aligned} R_x &= 6 \times 2/6 + 2 \\ &= 12/8 \\ &= 1.5 \Omega \end{aligned}$$

The equivalent resistance R_T of R_1 , R_x and R_4 in series is:

$$\begin{aligned} R_T &= 2.5 + 1.5 + 4 = 8 \Omega \\ \text{Supply current } I &= V/R_T \\ &= 200/8 \\ &= 25\text{A} \end{aligned}$$

(b) The current flowing through R_1 and R_4 is 25A

The current flowing through R_2

$$= \left(\frac{R_3}{R_2 + R_3} \right) I = \left(\frac{2}{6 + 2} \right) 25$$

$$= \mathbf{6.25\text{A}}$$

The current flowing through R_3

$$= \left(\frac{R_2}{R_2 + R_3} \right) I = \left(\frac{6}{6 + 2} \right) 25$$

$$= \mathbf{18.75\text{A}}$$

(c) The equivalent circuit of Figure is
 p.d. across R1, i.e. $V_1 = IR_1 = (25)(2.5) = \mathbf{62.5V}$
 p.d. across Rx, i.e. $V_x = IR_x = (25)(1.5) = \mathbf{37.5V}$
 p.d. across R4, i.e. $V_4 = IR_4 = (25)(4) = \mathbf{100V}$
 Hence the p.d. across R2 = p.d. across R3 = $\mathbf{37.5V}$

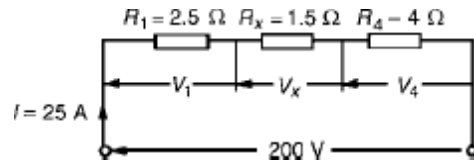

Problem 2: For the circuit shown in Figure 5.23 calculate (a) the value of resistor Rx such that the total power dissipated in the circuit is 2.5kW, and (b) the current flowing in each of the four resistors.

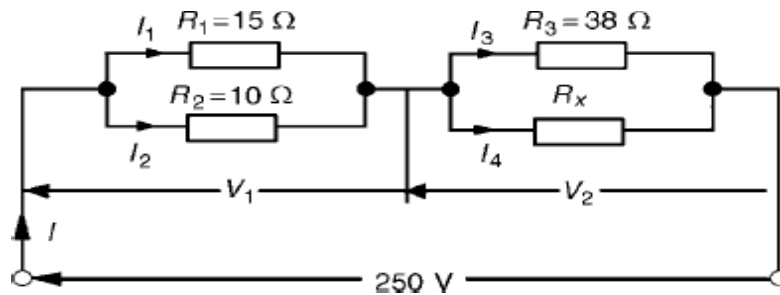

(a) Power dissipated $P = VI$ watts, hence $2500 = (250)(I)$
 i.e. $I = 2500/250$
 $= 10A$

From Ohm's law, $R_T = V/I = 250/10$
 $= 25 \Omega$, where R_T is the equivalent circuit resistance.

The equivalent resistance of R_1 and R_2 in parallel is
 $= 15 \times 10 / (15 + 10)$
 $= 150/25$
 $= 6 \Omega$

The equivalent resistance of resistors R_3 and R_x in parallel is equal to $25 \Omega - 6 \Omega$, i.e. 19Ω .
 There are three methods whereby R_x can be determined.

Problem 3: For the arrangement shown in Figure find the current I_x .

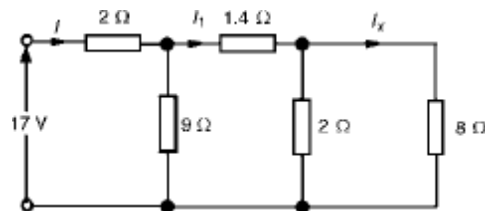

Commencing at the right-hand side of the arrangement shown in Figure, the circuit is gradually reduced in stages as shown in Figure

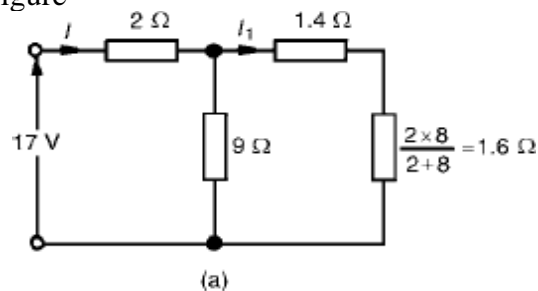

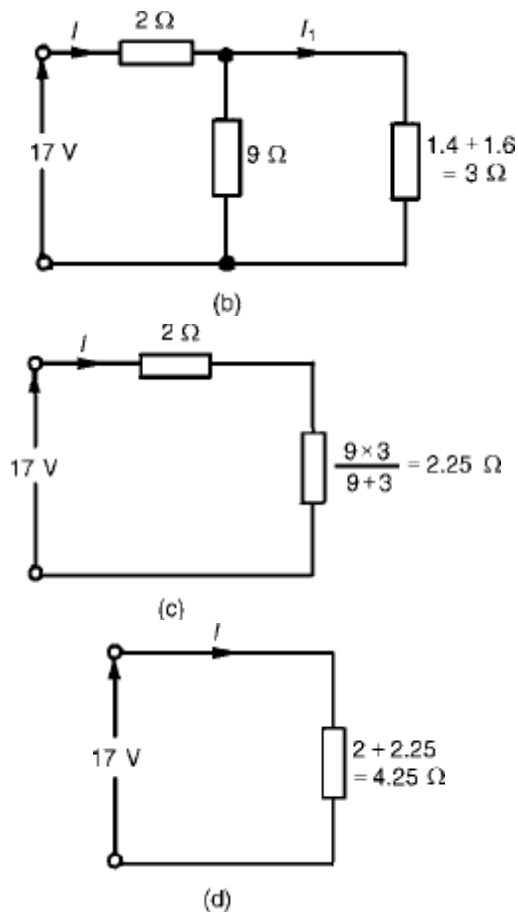

From Figure (d), $I = 17/4.25 = 4A$

From Figure (b), $I_1 = 9/9 + 3(I) = 12/4 = 3A$

From Figure, $I_x = 2/2 + 8(I_1) = 2/10(3) = 0.6A$

Source transformation:

Source transformation is defined as to convert the sources for easy analysis of circuit. In mesh analysis, it is easier if the circuit has voltage sources. In nodal analysis, it is easier if the circuit has current sources.

2.4. VOLTAGE SOURCE TO CURRENT SOURCE TRANSFORMATION:

If voltage source is converted to current source $I = \frac{V}{R_{se}}$ with parallel resistance equal to R_{se} .

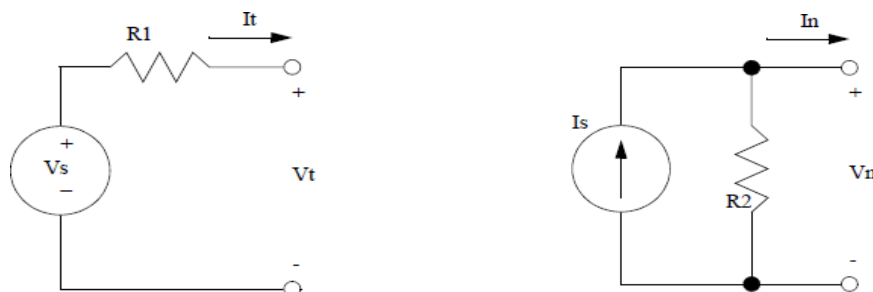

2.1. CURRENT SOURCE TO VOLTAGE SOURCE TRANSFORMATION:

If current source is converted to voltage source, then the voltage source series resistance equal to R_{sh} . $V = IR_{sh}$ with

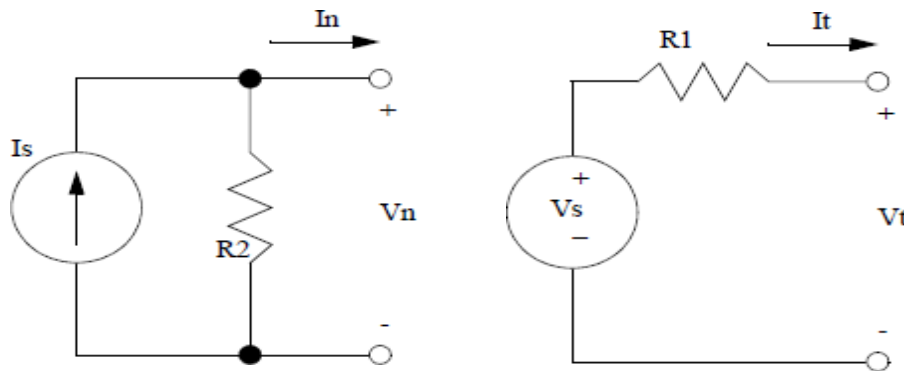

2.2. STAR DELTA CONVERSION:

In many circuit applications, we encounter components connected together in one of two ways to form a three-terminal network: the —Delta or Δ (also known as the —Pi, or π) configuration and the —Star (also known as the —Y) configuration.

Delta (Δ) network

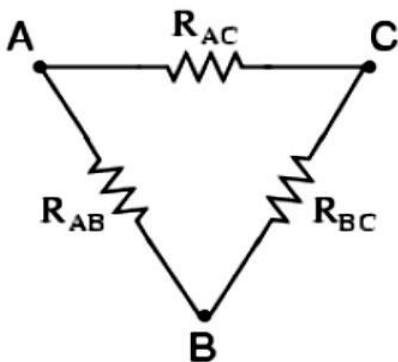

Wye (Y) network

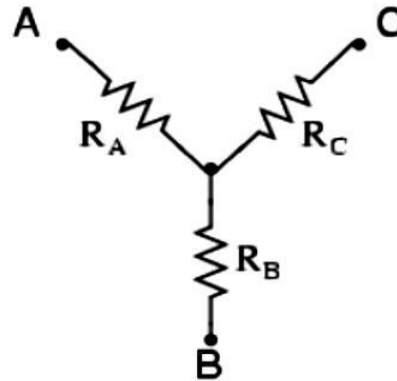

To convert a Delta (Δ) to a Wye (Y)

$$R_A = \frac{R_{AB} R_{AC}}{R_{AB} + R_{AC} + R_{BC}}$$

$$R_B = \frac{R_{AB} R_{BC}}{R_{AB} + R_{AC} + R_{BC}}$$

$$R_C = \frac{R_{AC} R_{BC}}{R_{AB} + R_{AC} + R_{BC}}$$

To convert a Wye (Y) to a Delta (Δ)

$$R_{AB} = \frac{R_A R_B + R_A R_C + R_B R_C}{R_C}$$

$$R_{BC} = \frac{R_A R_B + R_A R_C + R_B R_C}{R_A}$$

$$R_{AC} = \frac{R_A R_B + R_A R_C + R_B R_C}{R_B}$$

Problem 1: A star-connected load consists of three identical coils each of resistance 30Ω and inductance 127.3 mH . If the line current is 5.08 A , calculate the line voltage if the supply frequency is 50 Hz .

$$\begin{aligned} \text{Inductive reactance } X_L &= 2\pi fL \\ &= 2\pi (50) (127.3 \times 10^{-3}) \\ &= 40 \Omega \end{aligned}$$

$$\text{Impedance of each phase } Z_p = \sqrt{(R^2 + X_L^2)} = \sqrt{(30^2 + 40^2)} = 50 \Omega$$

$$\text{For a star connection } I_L = I_p = V_p / Z_p$$

$$\text{Hence phase voltage } V_p = I_p Z_p = (5.08)(50) = 254 \text{ V}$$

$$\text{Line voltage } V_L = \sqrt{3} V_p = \sqrt{3} (254) = 440 \text{ V}$$

Problem 2: A 415 V , 3-phase, 4 wire, star-connected system supplies three resistive loads as shown in Figure Determine (a) the current in each line and (b) the current in the neutral conductor.

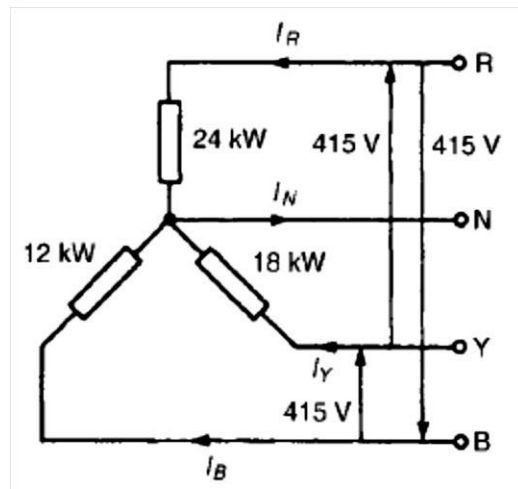

(a) For a star-connected system $V_L = \sqrt{3} V_p$

$$\text{Hence } V_p = \frac{V_L}{\sqrt{3}} = \frac{415}{\sqrt{3}} = 240 \text{ V}$$

Since current $I = \text{Power } P / \text{Voltage } V$ for a resistive load

$$\text{then } I_R = P_R / V_R = 24\,000 / 240 = 100 \text{ A}$$

$$I_Y = P_Y / V_Y = 18\,000 / 240 = 75 \text{ A}$$

$$\text{and } I_B = P_B / V_B = 12\,000 / 240 = 50 \text{ A}$$

(b) The three line currents are shown in the phasor diagram of Figure Since each load is resistive the currents are in phase with the phase voltages and are hence mutually displaced by 120° . The current in the neutral conductor is given by:

$I_N = I_R + I_Y + I_B$ phasorially.

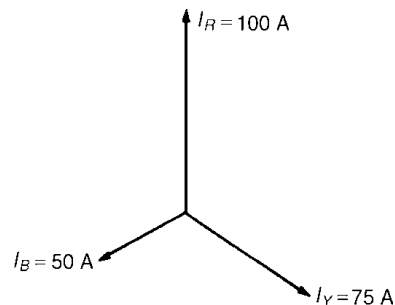

Figure shows the three line currents added phasorially. Oa represents I_R in magnitude and direction. From the nose of Oa , ab is drawn representing I_Y in magnitude and direction. From the nose of ab , bc is drawn representing I_B in magnitude and direction. Oc represents the resultant, I_N .

By measurement, $I_N = 43 \text{ A}$

Alternatively, by calculation, considering I_R at 90° , I_B at 210° and I_Y at 330° :

Total horizontal component = $100 \cos 90^\circ + 75 \cos 330^\circ + 50 \cos 210^\circ = 21.65$

Total vertical component = $100 \sin 90^\circ + 75 \sin 330^\circ + 50 \sin 210^\circ = 37.50$

Hence magnitude of IN = $\sqrt{(21.65^2 + 37.50^2)}$
 = 43.3A

Problem 3: Convert the given delta fig into equivalent star.

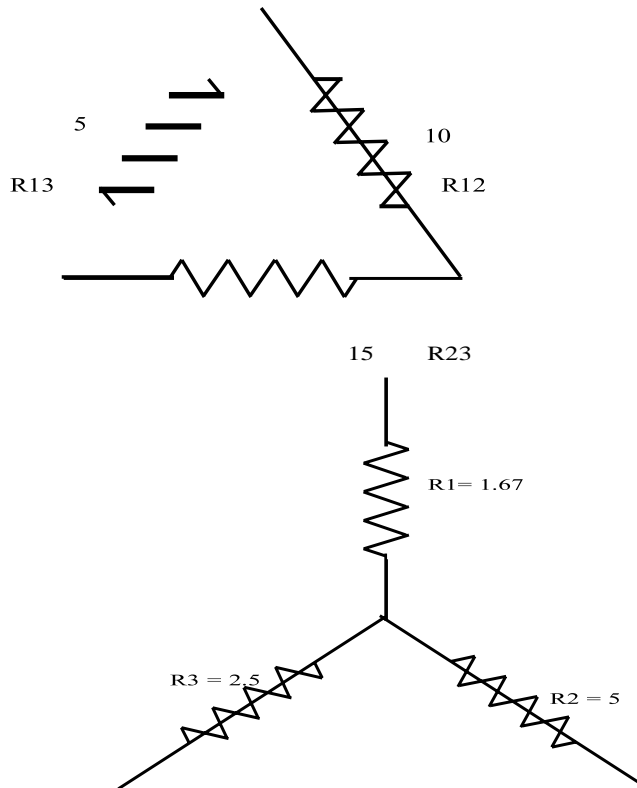

$$R_1 = \frac{R_{12} \times R_{13}}{R_{12} + R_{13} + R_{23}}$$

$$R_1 = \frac{10 \times 5}{30} = 1.67 \Omega$$

$$R_2 = \frac{10 \times 15}{30} = 5 \Omega$$

$$R_3 = \frac{5 \times 15}{30} = 2.5 \Omega$$

Problem 4: Convert the given star in fig into an equivalent delta.

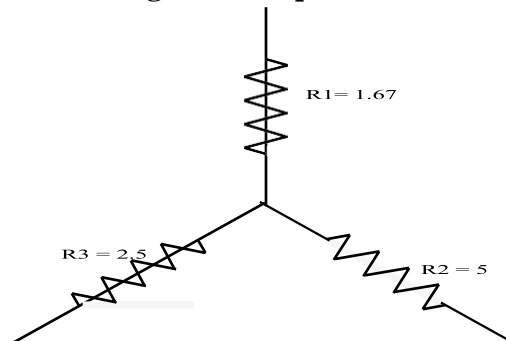

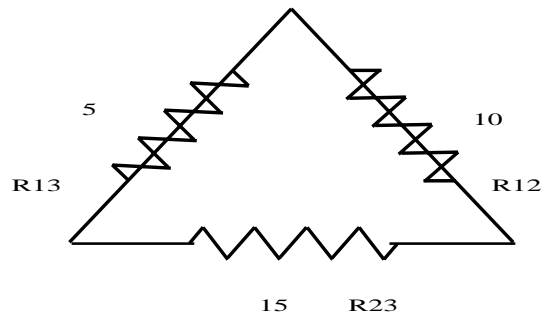

$$R_{12} = R_1 + R_2 + \frac{R_1 R_2}{R_3} = 1.67 \times 5 / 2.5 + 1.67 + 5 = 10 \Omega$$

$$R_{23} = 2.5 + 5 + \frac{2.5 \times 5}{1.67} = 15 \Omega$$

$$R_{31} = 2.5 + 1.67 + \frac{2.5 \times 1.67}{5} = 5 \Omega$$

Problem 5: Obtain the delta connected equivalent for the star connected circuit.

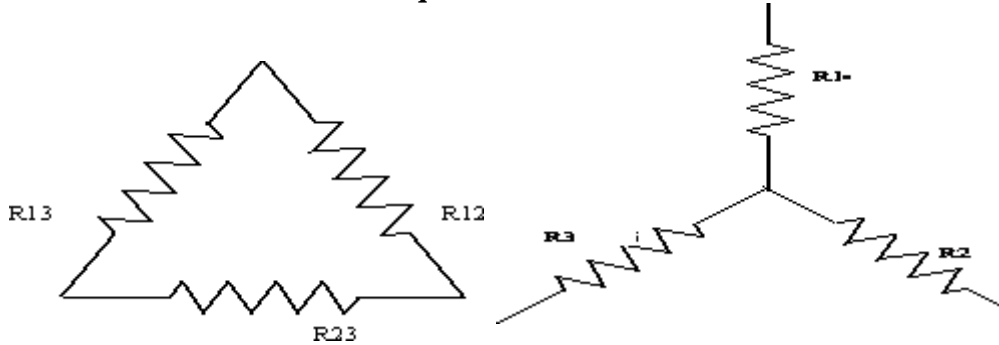

$$R_1 = 10 \Omega, R_2 = 20 \Omega, R_3 = 30 \Omega$$

$$R_{12} = \frac{R_1 R_2 + R_2 R_3 + R_3 R_1}{R_3} = \frac{10 \times 20 + 20 \times 30 + 30 \times 10}{30} = 36.67 \Omega$$

$$R = \frac{R_1 R_2 + R_2 R_3 + R_3 R_1}{R_3} = \frac{10 \times 20 + 20 \times 30 + 30 \times 10}{30} = 110$$

$$R_{31} = \frac{R_1 R_2 + R_2 R_3 + R_3 R_1}{R_2} = \frac{10 \times 20 + 20 \times 30 + 30 \times 10}{20} = 55 \Omega$$

Problem 6: Obtain the star connected equivalent for the delta connected circuit.

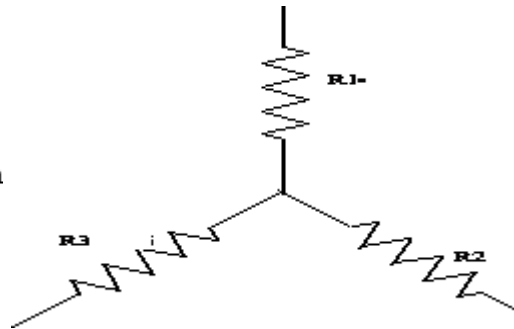
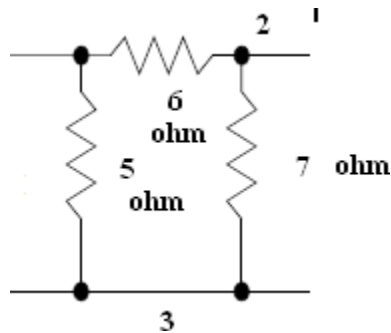

$$R_1 = \frac{R_{12} R_{31}}{R_{12} + R_{23} + R_{31}} = \frac{6 \times 5}{5 + 6 + 7} = 1.67 \Omega$$

$$R_2 = \frac{R_{23} R_{12}}{R_{12} + R_{23} + R_{31}} = \frac{6 \times 7}{5 + 6 + 7} = 2.33 \Omega$$

$$R_3 = \frac{R_{31} R_{23}}{R_{12} + R_{23} + R_{31}} = \frac{5 \times 7}{5 + 6 + 7} = 1.94 \Omega$$

2.3. THEVENINS THEOREM:

In circuit theory, **Thévenin's theorem** for linear electrical networks states that any combination of voltage sources, current sources, and resistors with two terminals is electrically equivalent to a single voltage source V and a single series resistor R . For single frequency AC systems the theorem can also be applied to general impedances, not just resistors.

The procedure adopted when using Thévenin's theorem is summarized below. To determine the current in any branch of an active network (i.e. one containing a source of e.m.f.):

- (i) remove the resistance R from that branch,
- (ii) determine the open-circuit voltage, E , across the break,
- (iii) remove each source of e.m.f. and replace them by their internal resistances and then determine the resistance, r , 'looking-in' at the break,

- (iv) determine the value of the current from the equivalent circuit shown in Figure 13.33, i.e. $I = \frac{E}{R+r}$

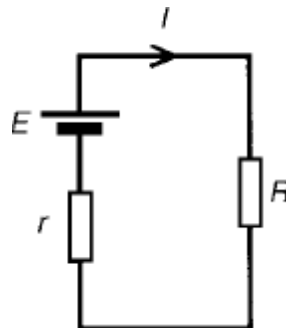

Problem 1: Use Thévenin's theorem to find the current flowing in the 10Ω resistor for the circuit shown in Figure

Following the above procedure:

- The 10Ω resistance is removed from the circuit as shown in Figure
-

There is no current flowing in the $5\ \Omega$ resistor and current I_1 is given by:

$$I_1 = 10/R_1 + R_2$$

$$= 10/2 + 8$$

$$= 1\text{A}$$

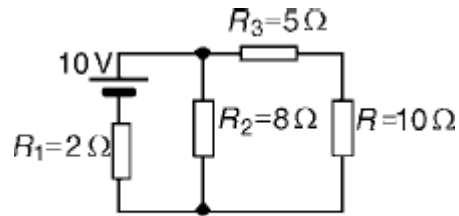

(a)

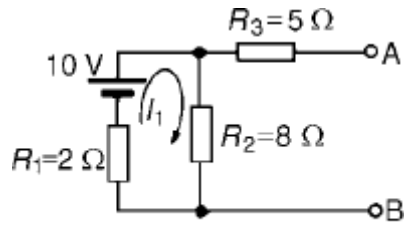

(b)

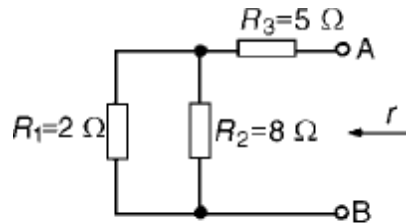

(c)

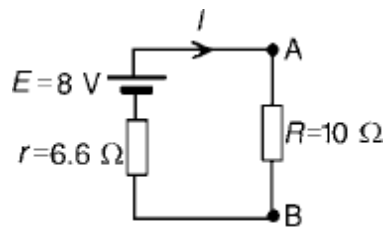

(d)

P.d. across $R_2 = I_1 R_2 = 1 \times 8 = 8\text{V}$ Hence p.d. across AB, i.e. the open-circuit voltage across the break, $E = 8\text{V}$

(iii) Removing the source of e.m.f. gives the circuit of Figure

Resistance, $r = R_3 + R_1 R_2 / R_1 + R_2$

$$= 5 + (2 \times 8 / 2 + 8)$$

$$= 5 + 1.6 = 6.6\ \Omega$$

(iv) The equivalent Thévenin's circuit is shown in Figure

Current $I = E / R + r = 8 / 10 + 6.6 = 8 / 16.6 = 0.482\text{A}$

Problem 2: For the network shown in Figure determine the current in the 0.8Ω resistor using Thévenin's theorem.

Following the procedure:

- The 0.8Ω resistor is removed from the circuit as shown in Figure
- Current $I_1 = 12/1+5+4 = 12/10 = 1.2\text{A}$

P.d. across 4Ω resistor $= 4I_1 = (4)(1.2) = 4.8\text{V}$

Hence p.d. across AB, i.e. the open-circuit voltage across AB, $E = 4.8\text{V}$

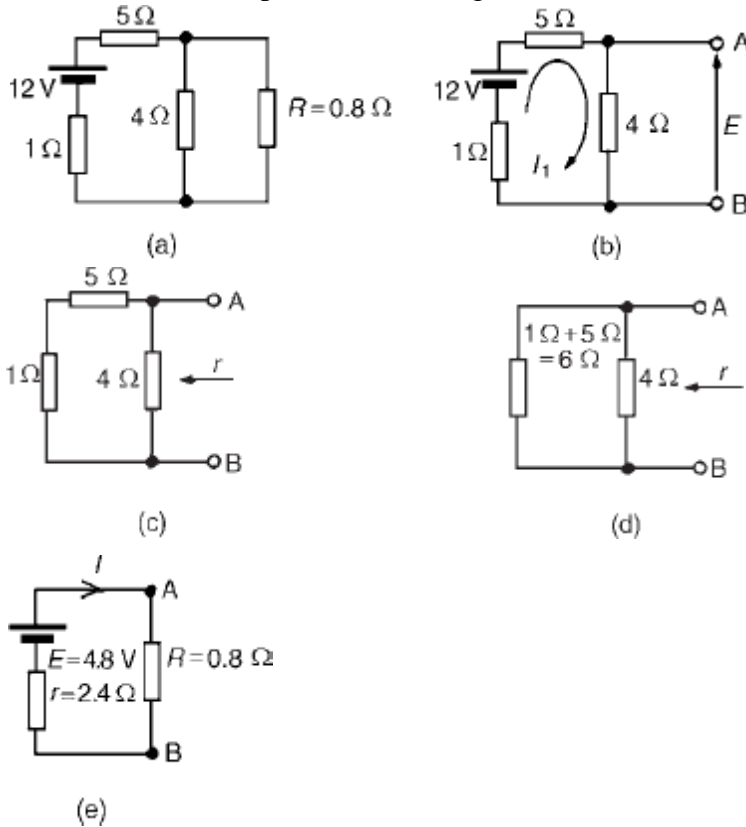

(iii) Removing the source of e.m.f. gives the circuit shown in Figure (c). The equivalent circuit of Figure

(c) is shown in Figure (d), from which, resistance $r = 4 \times 6 / 4 + 6 = 24/10 = 2.4 \Omega$

(iv) The equivalent Thévenin's circuit is shown in Figure (e), from which, current $I = E / r + R$
 $= 4.8 / 2.4 + 0.8$
 $= 4.8 / 3.2$

$I = 1.5\text{A} =$ current in the 0.8Ω resistor

Problem 3: Use Thévenin's theorem to determine the current I flowing in the $4\ \Omega$ resistor shown in Figure.

Find also the power dissipated in the $4\ \Omega$ resistor.

(i) The $4\ \Omega$ resistor is removed from the circuit as shown in Figure

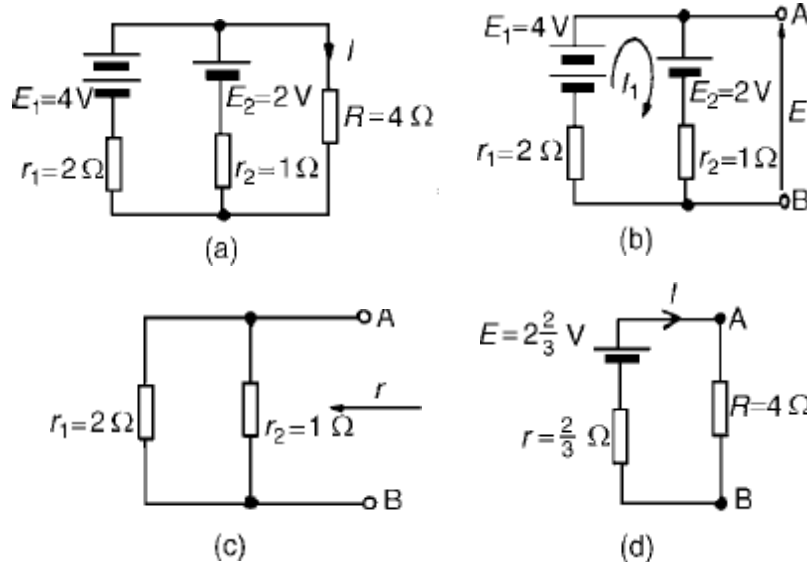

(ii) Current $I_1 = \frac{E_1 - E_2}{r_1 + r_2}$
 $= \frac{4 - 2}{2 + 1}$
 $= \frac{2}{3}\text{A}$

P.d. across AB, $E = E_1 - I_1 r_1 = 4 - \left(\frac{2}{3}\right)(2) = 2\frac{2}{3}\text{V}$

(iii) Removing the sources of e.m.f. gives the circuit shown in Figure (c), from which resistance

$r = 2 \times \frac{1}{2} + 1$
 $= \frac{2}{3}\ \Omega$

(iv) The equivalent Thévenin's circuit is shown in Figure(d), from which,

current, $I = \frac{E}{r + R} = \frac{2\frac{2}{3}}{\frac{2}{3} + 4} = \frac{8/3}{14/3}$
 $= \frac{8}{14}$
 $= 0.571\text{A}$

= current in the $4\ \Omega$ resistor

Problem 4: Power dissipated in $4\ \Omega$ resistor, $P = I^2 R = (0.571)^2 (4) = 1.304\text{W}$ Use Thévenin's theorem to determine the current flowing in the $3\ \Omega$ resistance of the network shown in Figure (a). The voltage source has negligible internal resistance.

i) The $3\ \Omega$ resistance is removed from the circuit as shown in Figure (b).

(ii) The $1\frac{2}{3}\ \Omega$ resistance now carries no current.

P.d. across $10\ \Omega$ resistor $= (10/10 + 5)(24)$

$= 16\text{V}$

Hence p.d. across AB, $E = 16\text{V}$

(iii) Removing the source of e.m.f. and replacing it by its internal resistance means that the $20\ \Omega$ resistance is short-circuited as shown in Figure (c) since its internal resistance is zero. The $20\ \Omega$ resistance may thus be removed as shown in Figure (d)

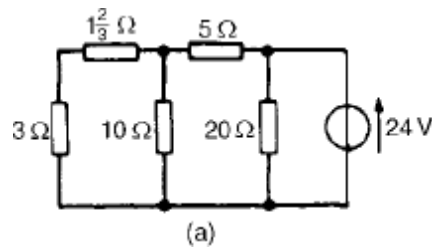

(a)

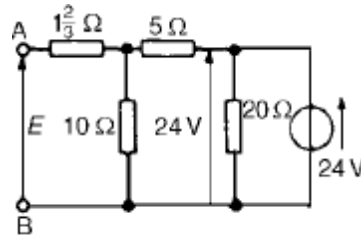

(b)

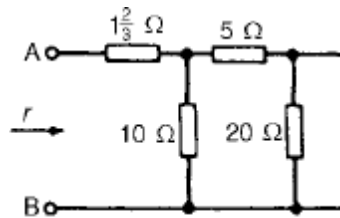

(c)

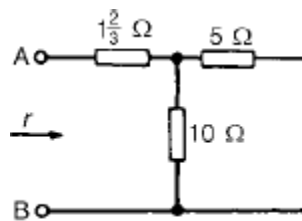

(d)

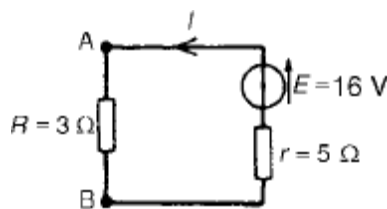

(e)

From Figure (d), resistance,

$$r = 1\frac{2}{3} + 10 \times \frac{5}{10+5} = 5\ \Omega$$

(iv) The equivalent Thévenin's circuit is shown in Figure (e), from which current, $I = \frac{E}{r+R} = \frac{16}{3+5} = \frac{16}{8} = 2\text{A}$

Problem 5: A Wheatstone Bridge network is shown in Figure (a). Calculate the current flowing in the $32\ \Omega$ resistor, and its direction, using Thévenin's theorem. Assume the source of e.m.f. to have negligible resistance.

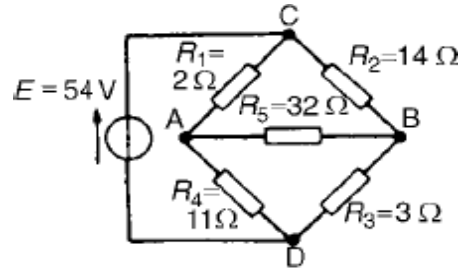

(a)

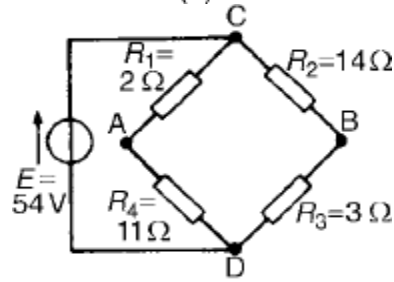

(b)

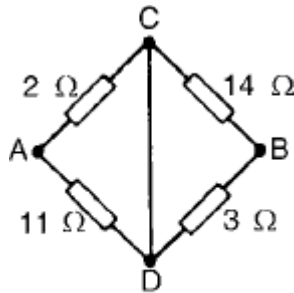

(c)

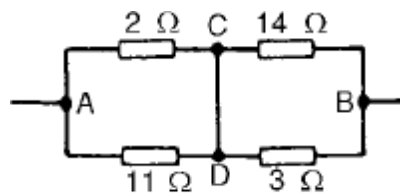

(d)

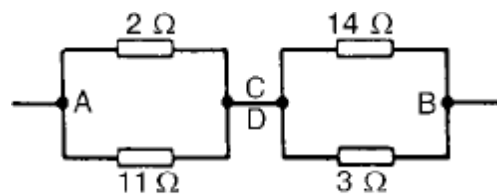

(e)

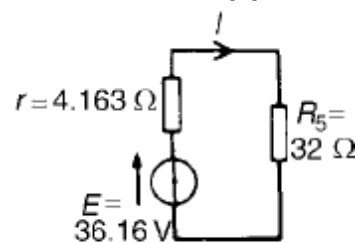

(f)

The $32\ \Omega$ resistor is removed from the circuit as shown in Figure (b)

The p.d. between A and C,

$$V_{AC} = R_1/R_1 + R_4 (E) = 2/2 + 11(54) = 8.31V$$

The p.d. between B and C,

$$V_{BC} = R_2/R_2 + R_3 (E) = 14/14 + 3(54) = 44.47V$$

Hence the p.d. between A and B = $44.47 - 8.31 = 36.16V$

Point C is at a potential of $+54V$. Between C and A is a voltage drop of $8.31V$. Hence the voltage at point A is $54 - 8.31 = 45.69V$. Between C and B is a voltage drop of $44.47V$. Hence the voltage at point B is $54 - 44.47 = 9.53V$. Since the voltage at A is greater than at B, current must flow in the direction A to B.

(iii) Replacing the source of e.m.f. with a short-circuit (i.e. zero internal resistance) gives the circuit shown in Figure (c). The circuit is redrawn and simplified as shown in Figure (d) and (e), from which the resistance between terminals A and B,

$$\begin{aligned} r &= 2 \times 11/2 + 11 + 14 \times 3/14 + 3 \\ &= 22/13 + 42/17 \\ &= 1.692 + 2.471 = 4.163\ \Omega \end{aligned}$$

(iv) The equivalent Thévenin's circuit is shown in Figure (f), from which, current $I = E/r + R_5$

$$\begin{aligned} &= 36.16/4.163 + 32 \\ &= 1A \end{aligned}$$

2.4. NORTON'S THEOREM:

- Norton's theorem states the following:
Any two-terminal linear bilateral dc network can be replaced by an equivalent circuit consisting of a current and a parallel resistor.
- The steps leading to the proper values of I_N and R_N .
- Preliminary steps:
 1. Remove that portion of the network across which the Norton equivalent circuit is found.
 2. Mark the terminals of the remaining two-terminal network.
 3. Finding R_N :
Calculate R_N by first setting all sources to zero and then finding the resultant resistance between the two marked terminals. Since $R_N = R_{Th}$ the procedure and value obtained using the approach described for Thévenin's theorem will determine the proper value of R_N .
 4. Finding I_N :
Calculate I_N by first returning all the sources to their original position and then finding the short-circuit current between the marked terminals. It is the same current that would be measured by an ammeter placed between the marked terminals.
 5. Draw the Norton equivalent circuit with the portion of the circuit previously removed replaced between the terminals of the equivalent circuit.

Problem 1: Use Norton's theorem to determine the current flowing in the $10\ \Omega$ resistance for the circuit shown in Figure

The branch containing the $10\ \Omega$ resistance is short circuited as shown in Figure

Figure (c) is equivalent to Figure (b). Hence

$$\begin{aligned} I_{SC} &= 10/2 \\ &= 5A \end{aligned}$$

If the $10V$ source of e.m.f. is removed from Figure (b) the resistance 'looking-in' at a break made

between A and B is given by:

$$r = 2 \times 8/2 + 8$$

$$= 1.6 \Omega$$

From the Norton equivalent network shown in Figure(d) the current in the 10Ω resistance, by current division, is given by:

$$I = (1.6/1.6 + 5 + 10) (5)$$

$$= 0.482\text{A}$$

as obtained previously in problem 7 using Thévenin's theorem.

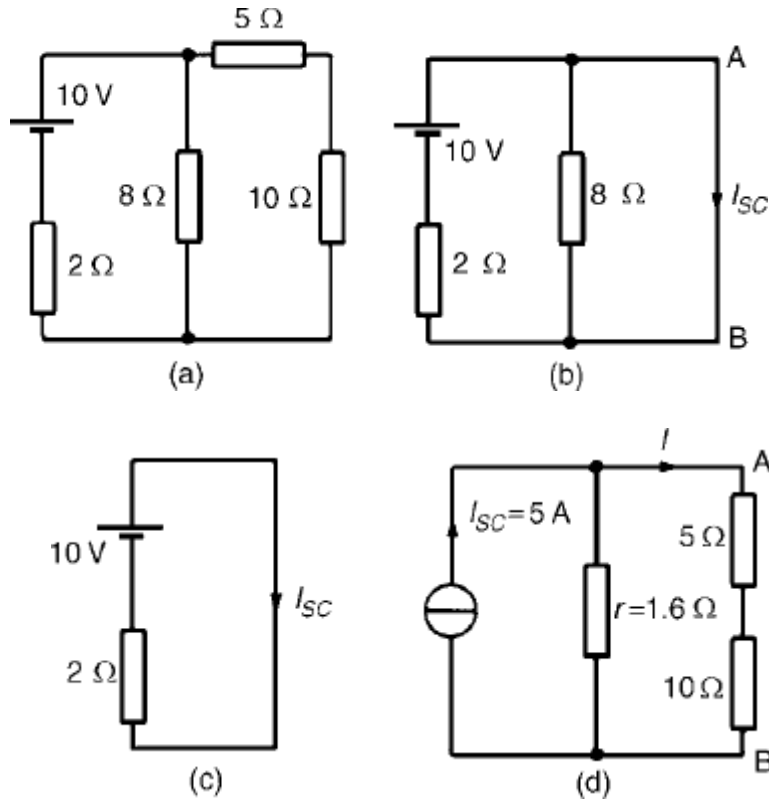

Problem 2: Use Norton's theorem to determine the current I flowing in the 4Ω resistance shown in Figure (a).

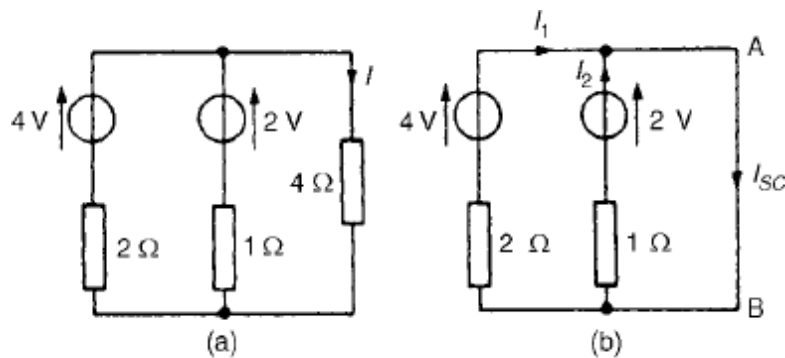

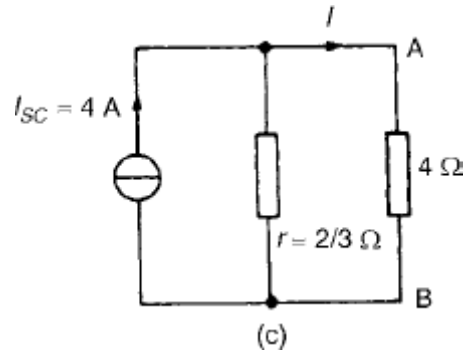

The $4\ \Omega$ branch is short-circuited as shown in Figure (b).

From Figure (b), $I_{SC} = I_1 + I_2 = 4\text{A}$

If the sources of e.m.f. are removed the resistance 'looking-in' at a break made between A and B is given by:

$$r = 2 \times 1/2 + 1 \\ = 2/3\ \Omega$$

From the Norton equivalent network shown in Figure (c) the current in the $4\ \Omega$ resistance is given by:

$$I = (2/3 / (2/3 + 4)) (4) = 0.571\text{A},$$

as obtained previously in problems 2, 5 and 9 using Kirchoff's laws and the theorems of superposition and Thévenin.

QUESTION BANK

PART-A

TWO MARKS

1. State Thevenin's theorem. [NOV/DEC'07] [MAY/JUNE'07] [NOV/DEC'04] (JUN-09) [MAY-11]

Any complex network consisting of linear, bilateral and lumped elements can be replaced by a simple circuit consisting of single voltage source in series with resistance.

It is also called as **Helmholtz's theorem**.

2. State Norton's theorem. [DEC-10]

Any complex network consisting of linear, bilateral and lumped elements can be replaced by a simple circuit consisting of single current source in parallel with resistance

3. State Superposition theorem. [NOV/DEC'04] [MAY/JUNE'07] [APR-08] [JUN-10]

In a linear, bilateral and lumped circuit elements that is energized by two or more sources, the response (current through or voltage across) in any resistor is equal to individual responses in it, when sources acts separately.

4. State Maximum power transfer theorem. [NOV/DEC'07] [NOV/DEC'06] [APR08] [JUN-12]

It states that the maximum power transferred to the load occurs when the load resistance is equal to the source resistance (equivalent resistance).

Condition for maximum power transfer $R_L = R_{TH}$

5. State Reciprocity theorem. [NOV/DEC'07]

It states that in a linear, bilateral, single source circuit, the ratio of excitation to response is constant when the position of excitation and response are interchanged.

6. Draw the Thevenin's equivalent circuit.

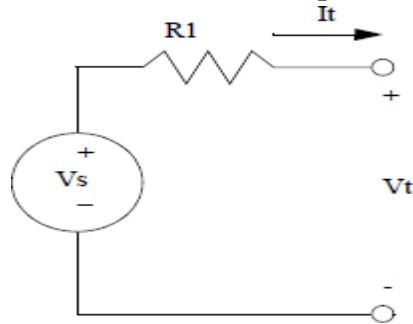

7. Draw the Norton's equivalent circuit

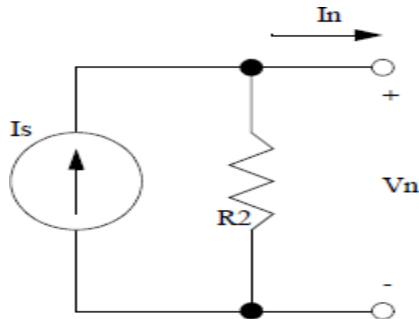

8. What are the applications of Thevenin's theorem?

1. To find the particular branch current in an electrical network while the resistance of that branch is varied with all other elements of the network remaining unchanged.
2. Used in sensitivity analysis.

9. What are the advantages of Thevenin's theorem?

1. Applicable to circuits containing any type of load – linear or non linear or time varying.
2. Applicable to circuits with load containing sources.
3. Applicable to circuits with load having initial conditions on passive elements.

10. What are the limitations of Thevenin's theorem?

1. Load should be connected to network containing linear elements only.
2. There should be no controlled source or magnetic coupling with the elements of load.

11. What are the applications of Maximum power transfer theorem? (AU-MAY08)

1. It is used for impedance matching.
2. It is used in communication circuits, where the power or circuit currents are low.

12. What are the limitations of Reciprocity theorem?

1. Only one source is present in the network.
2. Initial conditions should be zero.
3. The network is linear.
4. Impedance matrix is symmetric.
5. Dependent sources present in the network, even if they are linear, are excluded.

13. under what conditions, the super position theorem may be applied to the circuit. (JUN-09)

It is applicable to all time variant linear networks. It holds good for all possible locations, types and waveforms of the independent systems. The theorem applies both in time domain and frequency domain.

15. Write short notes about superposition theorem.

It is valid only for linear circuits. It is not valid for power responses. When the superposition theorem is applied to any circuit, the dependent voltage source in the circuit is always active.

16. State under what circumstances Thevenin's equivalent circuit is useful.

Thevenin's equivalent circuit is useful in the situation in which it is desirable to find a particular branch current in a network as the resistance of that branch is varied while all other resistances and sources remain constant.

17. What is meant by short and open circuits?

A short is conductor with zero resistance and an open is an infinitely large resistance. When we short circuit the resistance we replace the resistance by a conductor with zero resistance and when we open the circuit a resistance we remove the resistance.

18. Find the current through 10 resistor in the following circuit.

$$I_{5\Omega} = \frac{4 \times 10}{10 + 5 + 3} = \frac{40}{18} = 2.22A$$

19. Find the value of R_L for maximum power transfer.

Condition for maximum power transfer $R_L = R_{TH}$

$$R_{TH} = \frac{6 \times 6}{6 + 6} = 3\Omega$$

$$R_L = R_{TH} = 3\Omega$$

20. What is the property of additivity and homogeneity?

The principle of super position is a combination of additivity and homogeneity.

The property of additivity says that the response in a circuit due to number of sources is given by sum of response due to individual sources acting alone.

The property of homogeneity says that if all the sources are multiplied by a constant, then the response is also multiplied by the same constant.

21. Find the current I in the circuit.

When 2A source is acting alone.

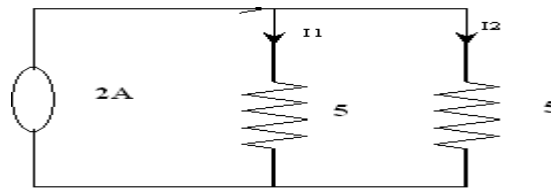

$$I_1 = \frac{2 \times 5}{10} = 1A$$

When 10V source is acting alone.

$$I_2 = \frac{10}{5 + 5} = 1A$$

When both sources are acting together $I=2A$

22. Find the thevenin's equivalent for the circuit shown. (APR-08)

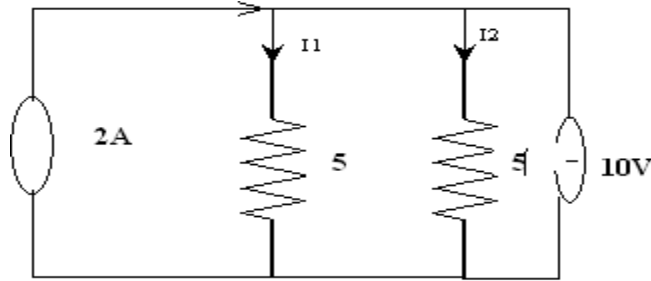

$$R_{th} = \frac{5 \times 5}{5 + 5} = 2.5\Omega$$

$$V_{th} = \frac{10 \times 5}{5 + 5} = 5V$$

23. Find the Norton's equivalent for the circuit shown.

$$I_{sc} = \frac{10}{5} = 2A$$

$$R_{TH} = \frac{5 \times 10}{5 + 10} = 6.667\Omega$$

UNIT III RESONANCE AND COUPLED CIRCUITS

Series and parallel resonance – their frequency response – Quality factor and Bandwidth - Self and mutual inductance – Coefficient of coupling – Tuned circuits – Single tuned circuits.

3.6. SERIES AND PARALLEL RESONANCE THEIR FREQUENCY RESPONSE

Series Resonance

The basic series-resonant circuit is shown in fig. 1. Of interest here is how the steady state amplitude and the phase angle of the current vary with the frequency of the sinusoidal voltage source. As the frequency of the source changes, the maximum amplitude of the source voltage (V_m) is held constant

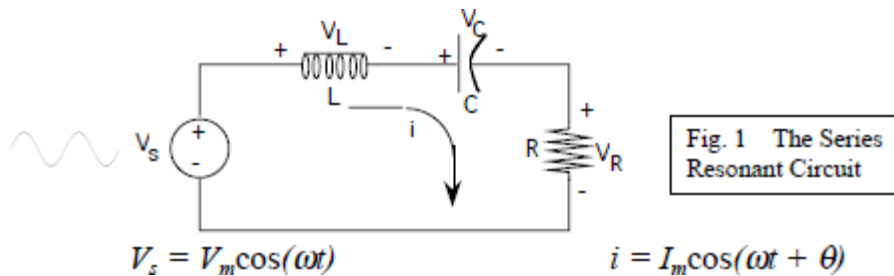

The frequency at which the reactance of the inductance and the capacitance cancel each other is the resonant frequency (or the unity power factor frequency) of this circuit. This occurs at

$$\omega_o = \frac{1}{\sqrt{LC}} \quad (1)$$

Since $i = V_R / R$, then the current i can be studied by studying the voltage across the resistor. The current i has the expression

$$i = I_m \cos(\omega t + \theta)$$

$$I_m = \frac{V_m}{\sqrt{R^2 + \left(\omega L - \frac{1}{\omega C}\right)^2}} \quad (2A)$$

$$\theta = -\tan^{-1} \left(\frac{\omega L - \frac{1}{\omega C}}{R} \right) \quad (2B)$$

The bandwidth of the series circuit is defined as the range of frequencies in which the amplitude of the current is equal to or greater than $(1 / \sqrt{2} = 0.707)$ times its maximum amplitude, as shown in fig. 2. This yields the bandwidth $B = \omega_2 - \omega_1 = R/L$

$$\omega_{2,1} = \sqrt{\left(\frac{R}{2L}\right)^2 + \frac{1}{LC}} \pm \frac{R}{2L} \quad (3)$$

are called the half power frequencies or the 3 dB frequencies, i.e the frequencies at which the value of I_m equals the maximum possible value divided by $\sqrt{2} = 1.414$.

The quality factor

$$Q = \frac{\omega_o}{B} = \frac{1}{R} \sqrt{\frac{L}{C}} \quad (4)$$

Then the maximum value of :

➤ VR occurs at $\omega = \omega_0$ (5B)

➤ VL occurs at

➤ VC occurs at $\omega_0 \sqrt{1 - \frac{R^2 C}{2L}}$ (5C)

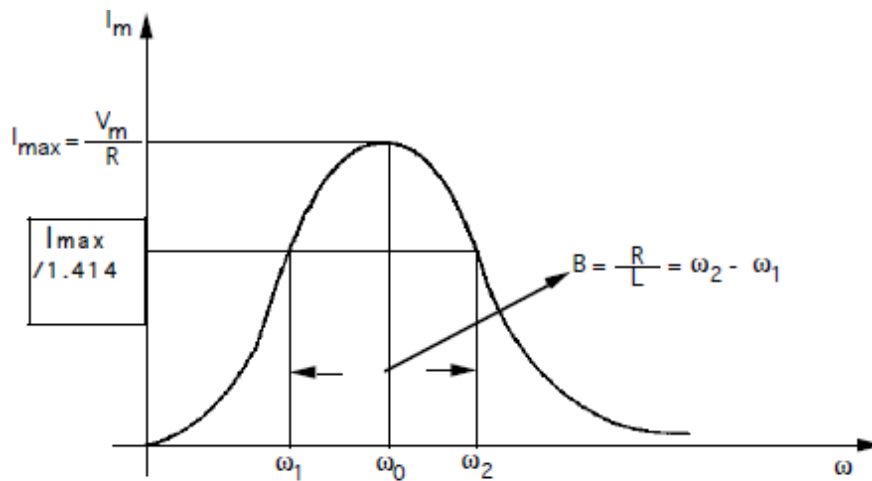

Fig. 2 Frequency Response of a Series - Resonant Circuit

Parallel Resonance:

The basic parallel-resonant circuit is shown in fig. 3. Of interest here in how the steady state amplitude and the phase angle of the output voltage V0 vary with the frequency of the sinusoidal voltage source.

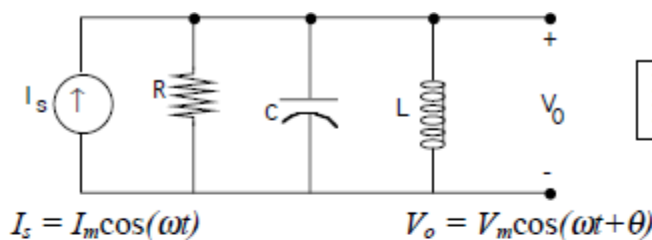

Fig. 3 The Parallel Resonant circuit

If $I_s = I_m \cos(\omega t)$, then $V_o = V_m \cos(\omega t + \theta)$ where

$$V_m = \frac{I_m}{\sqrt{\frac{1}{R^2} + \left(\omega C - \frac{1}{\omega L}\right)^2}} \quad (6A)$$

and

$$\theta = -\tan^{-1}\left(R\left(\omega C - \frac{1}{\omega L}\right)\right) \quad (6B)$$

The resonant frequency is

$$\omega_0 = \frac{1}{\sqrt{LC}}$$

The 3 dB frequencies are:

$$\therefore \omega_{2,1} = \sqrt{\left(\frac{1}{2RC}\right)^2 + \frac{1}{LC}} \pm \frac{1}{2RC} \quad (7)$$

The bandwidth

$$B = \omega_2 - \omega_1 = 1/RC.$$

The quality factor

$$Q = \frac{\omega_o}{B} = R\sqrt{\frac{C}{L}} \quad (8)$$

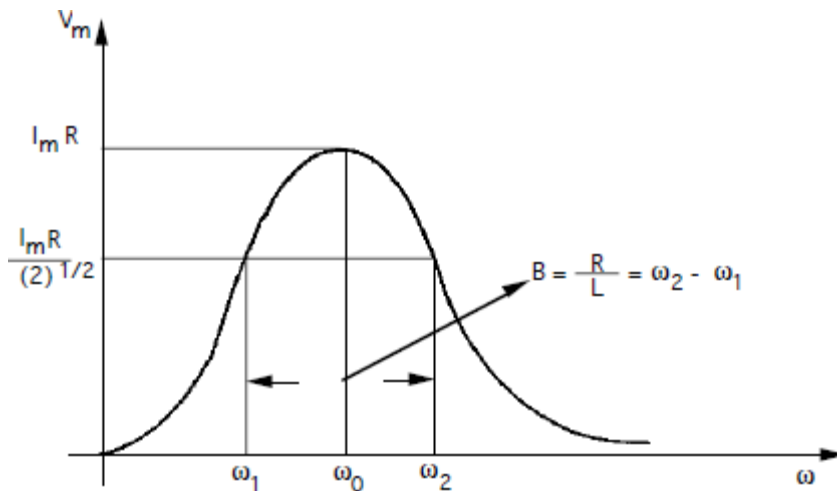

Fig. 4 Frequency Response of the Parallel - Resonant Circuit

3.6. QUALITY FACTOR AND BANDWIDTH

Quality factor, Q

Reactive components such as capacitors and inductors are often described with a figure of merit called Q. While it can be defined in many ways, it's most fundamental description is:

$$Q = \omega \frac{\text{energy stored}}{\text{average power dissipated}}$$

Thus, it is a measure of the ratio of stored vs. lost energy per unit time. Note that this definition does not specify what type of system is required. Thus, it is quite general.

Recall that an ideal reactive component (capacitor or inductor) stores energy

$$E = \frac{1}{2} CV_{pk}^2 \quad \text{or} \quad \frac{1}{2} LI_{pk}^2$$

Since any real component also has loss due to the resistive component, the average power dissipated is

$$P_{avg} = \frac{1}{2} I_{pk}^2 R = \frac{V_{pk}^2}{2R}$$

If we consider an example of a series resonant circuit.

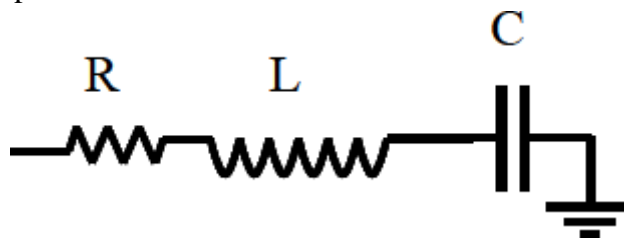

At resonance, the reactances cancel out leaving just a peak voltage, V_{pk} , across the loss

resistance, R. Thus, $I_{pk} = V_{pk}/R$ is the maximum current which passes through all elements. Then,

$$Q = \omega_0 \frac{LI_{pk}^2/2}{I_{pk}^2 R/2} = \frac{\omega_0 L}{R} = \frac{1}{\omega_0 RC}$$

In terms of the series equivalent network for a capacitor shown above, its Q is given by:

$$Q = \frac{1}{\omega RC} = \frac{X}{R}$$

where we pretend that the capacitor is resonated with an ideal inductor at frequency ω . X is the capacitive reactance, and R is the series resistance. Since this Q refers only to the capacitor itself, in isolation from the rest of the circuit, it is called unloaded Q or Q_U . The higher the unloaded Q, the lower the loss. Notice that the Q decreases with frequency.

The unloaded Q of an inductor is given by

$$Q_U = \frac{\omega_0 L}{R}$$

where R is a series resistance as described above. Note that Q is proportional to frequency for an inductor. The Q of an inductor will depend upon the wire diameter, core material (air, powdered iron, ferrite) and whether or not it is in a shielded metal can. It is easy to show that for a parallel resonant circuit, the Q is given by susceptance/conductance:

$$Q = \frac{B}{G}$$

where B is the susceptance of the capacitor or inductor and G is the shunt conductance.

Bandwidth:

At a certain frequency the power dissipated by the resistor is half of the maximum power which as mentioned occurs at

$$\omega_0 = \frac{1}{\sqrt{LC}}$$

The half power occurs at the frequencies for which the amplitude of the voltage across the resistor becomes equal to

$$\frac{1}{\sqrt{2}}$$

of the maximum.

$$P_{1/2} = \frac{1}{4} \frac{V_{max}^2}{R}$$

Figure shows in graphical form the various frequencies of interest.

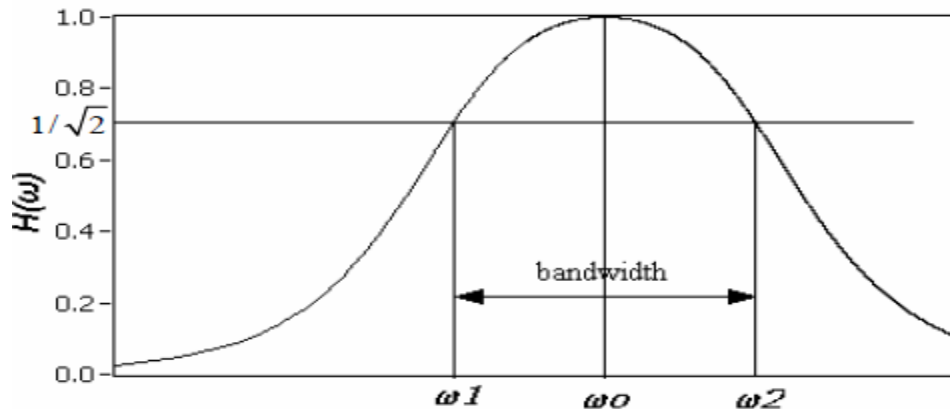

Therefore, the $\frac{1}{2}$ power occurs at the frequencies for which

$$\frac{1}{\sqrt{2}} = \frac{\omega RC}{\sqrt{(1 - \omega^2 LC)^2 + (\omega RC)^2}}$$

Equation has two roots

$$\omega_1 = -\frac{R}{2L} + \sqrt{\left(\frac{R}{2L}\right)^2 + \frac{1}{\omega_0^2}}$$

$$\omega_2 = \frac{R}{2L} + \sqrt{\left(\frac{R}{2L}\right)^2 + \frac{1}{\omega_0^2}}$$

$$\text{Bandwidth} = B = \omega_2 - \omega_1$$

By multiplying these two Equations we can show that ω_0 is the geometric mean of ω_1 and ω_2 .

$$\omega_0 = \sqrt{\omega_1 \omega_2}$$

As we see from the plot on Figure 2 the bandwidth increases with increasing R. Equivalently the sharpness of the resonance increases with decreasing R.

For a fixed L and C, a decrease in R corresponds to a narrower resonance and thus a higher selectivity regarding the frequency range that can be passed by the circuit.

As we increase R, the frequency range over which the dissipative characteristics dominate the behavior of the circuit increases. In order to quantify this behavior we define a parameter called the Quality Factor Q which is related to the sharpness of the peak and it is given by

$$Q = 2\pi \frac{\text{maximum energy stored}}{\text{total energy lost per cycle at resonance}} = 2\pi \frac{E_s}{E_d}$$

Which represents the ratio of the energy stored to the energy dissipated in a circuit.

The energy stored in the circuit is

$$E_s = \frac{1}{2} LI^2 + \frac{1}{2} CVc^2$$

For $Vc = A \sin \omega t$ the current flowing in the circuit is

$$I = C \frac{dVc}{dt} = \omega CA \cos(\omega t)$$

The total energy stored in the reactive elements is

$$E_s = \frac{1}{2} L \omega^2 C^2 A^2 \cos^2(\omega t) + \frac{1}{2} CA^2 \sin^2(\omega t)$$

At the resonance frequency where

$$\omega = \omega_0 = \frac{1}{\sqrt{LC}}$$

the energy stored in the circuit becomes

$$E_s = \frac{1}{2} CA^2$$

The energy dissipated per period is equal to the average resistive power dissipated times the oscillation period.

$$E_D = R \langle I^2 \rangle \frac{2\pi}{\omega_0} = R \left(\frac{\omega_0^2 C^2 A^2}{2} \right) \frac{2\pi}{\omega_0} = 2\pi \left(\frac{1}{2} \frac{RC}{\omega_0 L} A^2 \right)$$

And so the ratio Q becomes

By combining these Equations we obtain the relationship between the bandwidth and the Q factor.

$$B = \frac{L}{R} = \frac{\omega_0}{Q}$$

Summary of the properties of RLC resonant circuits.

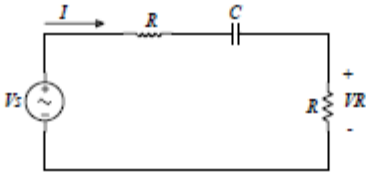
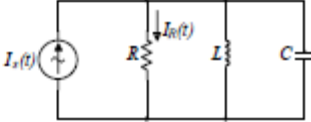
	Series	Parallel
Circuit		
Transfer function	$ H(\omega) \equiv \left \frac{VR}{V_s} \right = \frac{\omega RC}{\sqrt{(1 - \omega^2 LC)^2 + (\omega RC)^2}}$	$ H(\omega) = \left \frac{I_R}{I_s} \right = \frac{\omega L}{\sqrt{(R - \omega^2 LCR)^2 + (\omega L)^2}}$
Resonant frequency	$\omega_0 = \frac{1}{\sqrt{LC}}$	$\omega_0 = \frac{1}{\sqrt{LC}}$
½ power frequencies	$\omega_1 = -\frac{R}{2L} + \sqrt{\left(\frac{R}{2L}\right)^2 + \frac{1}{\omega_0^2}}$ $\omega_2 = \frac{R}{2L} + \sqrt{\left(\frac{R}{2L}\right)^2 + \frac{1}{\omega_0^2}}$	$\omega_1 = -\frac{1}{2RC} + \sqrt{\left(\frac{1}{2RC}\right)^2 + \frac{1}{\omega_0^2}}$ $\omega_2 = \frac{1}{2RC} + \sqrt{\left(\frac{1}{2RC}\right)^2 + \frac{1}{\omega_0^2}}$
Bandwidth	$B_s = \omega_2 - \omega_1 = \frac{R}{L}$	$B_p = \omega_2 - \omega_1 = \frac{1}{RC}$
Q factor	$Q = \frac{\omega_0}{B_s} = \frac{\omega_0 L}{R} = \frac{1}{\omega_0 RC}$	$Q = \frac{\omega_0}{B_p} = \omega_0 RC = \frac{R}{\omega_0 L}$

QUESTION BANK

PART-A

TWO MARKS

1. Define resonance. What is the condition for resonance for an RLC series circuit?

[MAY/JUNE'07] (JUN-09)[DEC-10]

A circuit is said to be in resonance when the applied voltage and current are in phase. For an RLC series circuit, at resonance the inductive and capacitive reactance are equal.

2. How the RLC series circuit behaves for the frequencies above and below the resonant frequencies.

For frequencies below resonant frequency, the capacitive reactance is more than the inductive reactance. Therefore the equivalent reactance is equal to capacitive and the circuit behaves like a RC circuit.

For frequencies above resonant frequency, the inductive reactance is more than the capacitive reactance. Therefore the equivalent reactance is equal to inductive and the circuit behaves like a RL circuit.

3. Derive the expression for resonant frequency.[MAY/JUNE'07][JUNE-12]

At resonance condition, the inductive and capacitive reactances are equal.

$$X_L = X_C$$

$$2\pi fL = \frac{1}{2\pi fC}$$

$$f^2 = \frac{1}{4\pi^2 LC}$$

$$f_r = f_o = \frac{1}{2\pi\sqrt{LC}}$$

4. Define resonant frequency.[MAY/JUNE'05] (JUN-08)

The frequency at resonance is called as resonant frequency.

It is also defined as the geometric mean of two half power frequencies is called resonant frequency.

$$f_o = \sqrt{f_1 f_2}$$

5. Draw the phasor diagrams for series RLC circuit.

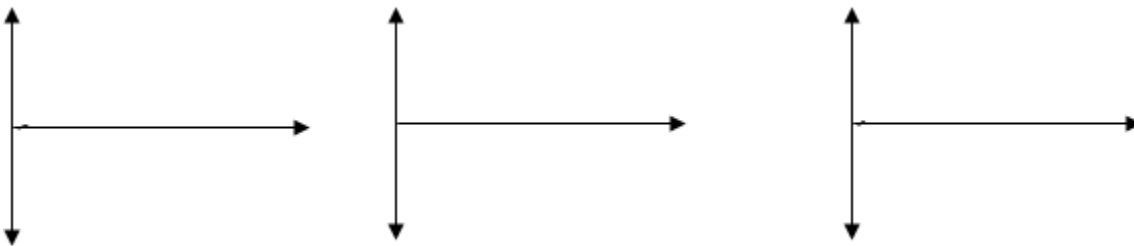

6. Draw the curves for variation of impedance, admittance and current with frequency in RLC series resonance circuit.

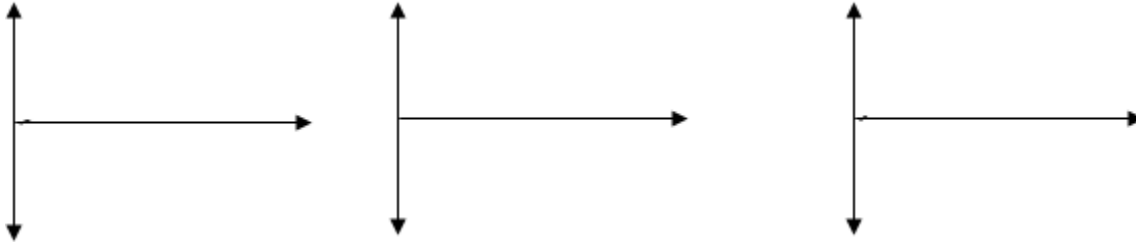

7. Define Q factor.[NOV/DEC'03] (JUN-09)[MAY-11]

It is the ratio between capacitor voltage or inductor voltage at resonance to supply voltage is called as Q-factor or quality factor.

$$Q \text{ factor} = \frac{\text{capacitor voltage or inductor voltage}}{\text{supply voltage}}$$

It is also defined as

$$Q \text{ factor} = 2\pi \times \frac{\text{Maximum energy stored}}{\text{Energy dissipated per cycle}}$$

$$Q \text{ factor} = \frac{\omega o L}{R} = \frac{1}{\omega o RC} = \frac{1}{R} \sqrt{\frac{L}{C}} = \frac{f o}{B.W}$$

8. Define Bandwidth. (JUN-09)

It is defined as the width of the resonant curve upto frequency at which the power in the circuit is half of its maximum value. The difference between two half power frequencies is also called as band width.

9. Define selectivity.

It is the ratio of bandwidth to resonant frequency.

$$\text{Selectivity} = \frac{\text{Band width}}{\text{Re sonant frequency}} = \frac{f_2 - f_1}{f_0}$$

Selectivity of a resonant circuit is its ability to discriminate between signals of desired and undesired frequencies.

10. Define half power frequencies.



The frequencies at which the power in the circuit is half of its maximum value are called as half power frequencies.

f₁=lower cut-off frequency

f₂=upper cut-off frequency

11. Give the relationship between

a) Band width, resonant frequency and quality factor

$$Q_0 = \frac{f_0}{f_2 - f_1} = \frac{\omega o L}{R}$$

b) Resonant frequency and half power frequencies

$$\omega_o = \sqrt{\omega_1 \omega_2}$$

c) Quality factor in terms of R, L and C

$$Q = \frac{1}{R} \sqrt{\frac{L}{C}}$$

12. In series resonance circuit, on resonance the following will occur

- a) $V=V_R$ b) $X_L=X_C$ c) $Z=R$ d) $V_L=V_C$ e) all the above

ANS: all the above

13. What inductance will give the same reactance as a capacitor of $2\mu\text{f}$ when both are at 50HZ?

The inductive and capacitive reactances are same

$$X_L = X_C$$

$$2\pi fL = \frac{1}{2\pi fC}$$

$$4\pi^2 f^2 L = \frac{1}{C}$$

$$L = \frac{1}{4\pi^2 f^2 C} = \frac{1}{4\pi^2 (0^2) (\times 10^{-6})} = 5H$$

14. A series resonant circuit is capacitive at $f=150\text{ HZ}$, The circuit will be inductive some where at

- a) f greater than 150HZ
 b) f equal to 150HZ
 c) f less than 150HZ
 d) None of the above

ANS: f greater than 150HZ

15. A series RLC circuit has $R=50\Omega$; $L=100\mu\text{H}$; and $C=300\text{pF}$, $v=20\text{V}$. What is the current at resonance?

$$I = \frac{V}{R} = \frac{20}{50} = 0.4\text{ A}$$

16. An RLC circuit consists of a resistance of 1000W, an inductance of 100 mH and a capacitance of $10\mu\text{F}$. The Q factor of the circuit is

$$Q = \frac{1}{R} \sqrt{\frac{L}{C}} = \frac{1}{1000} \sqrt{\frac{100 \times 10^{-3}}{10 \times 10^{-6}}} = 0.1$$

17. Write the characteristics of series resonance.

A series RLC circuit, at resonance condition

- i) The power factor is unity
- ii) Impedance of the circuit is minimum
- iii) Admittance of the circuit is maximum
- iv) Current is maximum
- v) The magnitude of the voltage across inductance and capacitance will be Q times the supply voltage, but they are in phase opposition.

18. Write the expression for half power frequencies of RLC series circuit.

$$\text{Lower cut-off frequency } f_1 = \frac{1}{2\pi} \left[-\frac{R}{2L} + \sqrt{\left(\frac{R}{2L}\right)^2 + \frac{1}{LC}} \right] \text{ or } \left[-\frac{1}{2Q_r} + \sqrt{1 + \frac{1}{4Q_r^2}} \right]$$

$$\text{Upper cut-off frequency } f_2 = \frac{1}{2\pi} \left[\frac{R}{2L} + \sqrt{\left(\frac{R}{2L}\right)^2 + \frac{1}{LC}} \right] \text{ or } \left[\frac{1}{2Q_r} + \sqrt{1 + \frac{1}{4Q_r^2}} \right]$$

19. An RLC series circuit has R=10Ω, X_C=62.833 Ω. Find the value of L for resonance at 50HZ.

$$\text{At resonance, } X_L = X_C \quad X_C = 62.833\Omega$$

$$X_L = 2\pi fL, \text{ Inductance, } L = \frac{X_L}{2\pi f} = \frac{62.833}{2\pi \times 50} = 0.2 \text{ H}$$

20. Determine the quality factor of the RLC series circuit with R=10Ω, L=0.01 H and c=100μF.

$$\text{Quality factor at resonance } Q_r = \frac{1}{R} \sqrt{\frac{L}{C}} = \frac{1}{10} \sqrt{\frac{0.01}{100 \times 10^{-6}}} = 1$$

21. A series RLC circuit is excited with 10V sinusoidal source resonate at a frequency of 50HZ. If the bandwidth is 5HZ. What will the voltage across capacitance?

$$\text{Quality factor at resonance} = Q_r = \frac{f_o}{B.W} = \frac{50}{5} = 10$$

$$\text{Voltage across capacitor} = Q_r V = 10 \times 10 = 100V$$

22. A series RLC circuit has R=10Ω, X_C=20 Ω and X_L=20 Ω is excited by a sinusoidal source of voltage 200V. What will the voltage across inductance.

$$\text{Quality factor at resonance} = Q_r = \frac{\omega^o L}{R} = \frac{X_L}{R} = \frac{20}{10} = 2$$

$$\text{Voltage across inductor} = Q_r V = 2 \times 200 = 400V$$

23. The impedance and quality factor of a RLC series circuit at $\omega=10^7$ rad/sec are $100+j0$ and 100 respectively. Find the values of R, L and C.

Given

$$\omega = 10^7 \text{ rad/sec}$$

$$\text{Impedance} = 100 + j0$$

$$\text{Quality factor} = 100$$

At resonance $Z=R$, Resistance=100Ω

$$\text{Quality factor } Q_r = \frac{\omega^o L}{R}$$

$$\text{Inductance} = L = \frac{Q_r R}{\omega} = \frac{100 \times 100}{10^7} = 1 \text{ mH}$$

$$\omega_o^2 = \frac{1}{LC}$$

$$C = \frac{1}{\omega_o^2 L} = \frac{1}{(10^7)^2 \times 1 \times 10^{-3}} = 10 \text{ pF}$$

24. What is anti resonance?

In RLC parallel circuit, the current is minimum at resonance whereas in series resonance the current is maximum. Therefore the parallel resonance is called anti-resonance.

25. Write the expressions for quality factor of parallel RLC circuit.

$$Q \text{ factor} = \frac{R}{\omega_0 L} = \omega_0 RC = R \sqrt{\frac{C}{L}} = \frac{f_0}{B.W}$$

26. Write the expression for half power frequencies of parallel RLC circuit.

$$\text{Lower cut-off frequency } f_1 = \frac{1}{2\pi} \left[-\frac{1}{RC} + \sqrt{\left(\frac{1}{2RC}\right)^2 + \frac{1}{LC}} \right] \text{ or } \left[-\frac{1}{2Q_r} + \sqrt{1 + \frac{1}{4Q_r^2}} \right]$$

$$\text{Upper cut-off frequency } f_2 = \frac{1}{2\pi} \left[\frac{1}{RC} + \sqrt{\left(\frac{1}{2RC}\right)^2 + \frac{1}{LC}} \right] \text{ or } \left[\frac{1}{2Q_r} + \sqrt{1 + \frac{1}{4Q_r^2}} \right]$$

27. What is dynamic resistance? Write the expression for dynamic resistance of RL circuit parallel with C.

The resistance of the RLC parallel circuit at resonance is called dynamic resistance.

$$R_{\text{dynamic}} = \frac{L}{CR}$$

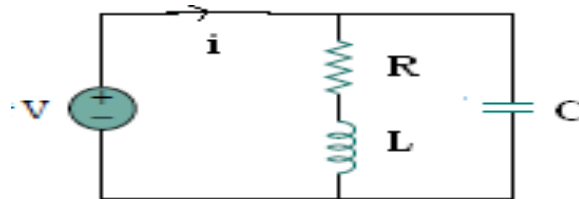

28. Write the characteristics of parallel resonance.

- i) At resonance, admittance is minimum and equal to conductance, therefore current is minimum.
- ii) Below resonant frequency, the circuit behaves as inductive circuit and above resonant frequency, the circuit behaves as capacitive circuit.
- iii) At resonance, the magnitude of current through inductance and capacitance will be Q times the current supplied by the source, but they are in phase opposition.

29. Draw the curves for variation of impedance, admittance and current with frequency in RLC parallel resonance circuit.

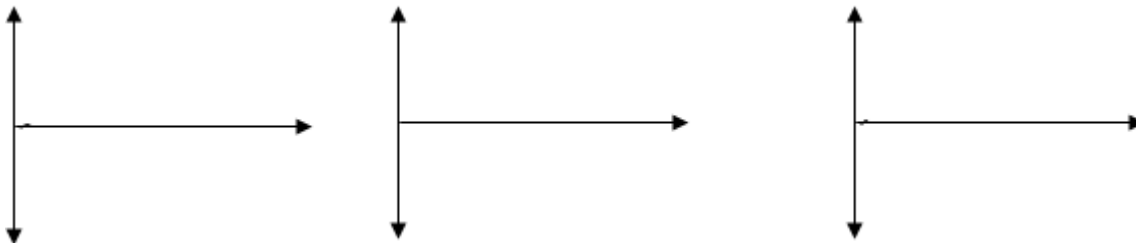

30. Compare the series and parallel resonant circuit.(consider practical parallel resonant circuit)

Description	Series RLC circuit	Parallel RLC circuit
Impedance at resonance	Minimum	Maximum
Current at resonance	Maximum= $\frac{V}{R}$	Minimum= $\frac{VCR}{L}$
Effective impedance	R	$\frac{L}{CR}$
Power factor at resonance	Unity	Unity
Resonant frequency	$\frac{1}{2\pi\sqrt{LC}}$	$\frac{1}{2\pi\sqrt{\frac{1}{LC} - \frac{R^2}{L^2}}}$
It magnifies	Voltage	Current
Magnification is	$\frac{\omega L}{R}$	$\frac{\omega L}{R}$

31. Why is a series resonance circuit regarded as acceptor circuit?

A series resonance circuit has a capability to draw heavy currents and power from the mains. So it is regarded as acceptor circuit.

32. Why is a parallel resonance circuit regarded as rejecter circuit?

A parallel resonance circuit has a capability to very small currents and power from the mains. So it is regarded as rejecter circuit.

33. A coil of resistance R, an inductance L is shunted by a capacitor C and this parallel combination is under resonance. What is the resonant frequency of the circuit?

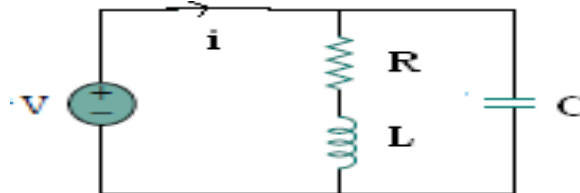

$$\text{Resonant frequency } f_0 = \frac{1}{2\pi\sqrt{\frac{1}{LC} - \left(\frac{R}{L}\right)^2}}$$

34. Find the resonant frequency in the ideal parallel RLC circuit with L=40 mH and c=0.01μF.

$$\text{Resonant frequency } f_0 = \frac{1}{2\pi\sqrt{LC}} = \frac{1}{2\pi\sqrt{40 \times 10^{-3} \times 0.01 \times 10^{-6}}} = 7958 \text{ HZ}$$

35. Draw the two branch parallel resonant circuit.

$$\text{Resonant frequency } f_0 = \frac{1}{2\pi\sqrt{LC}} \times \sqrt{\frac{\left(R_1^2 - \frac{L}{C}\right)}{\left(R_2^2 - \frac{L}{C}\right)}}$$

36. What is the nature of power factor if the frequency of operation is less than the resonance frequency in a RLC series circuit?

When the frequency is less than resonance frequency f_0 , the current lags behind the voltage. i.e., ϕ is leading in nature. Hence, the power factor is leading for frequency less than the resonance frequency.

37. Draw the variation of reactance with frequency in series resonance circuit.

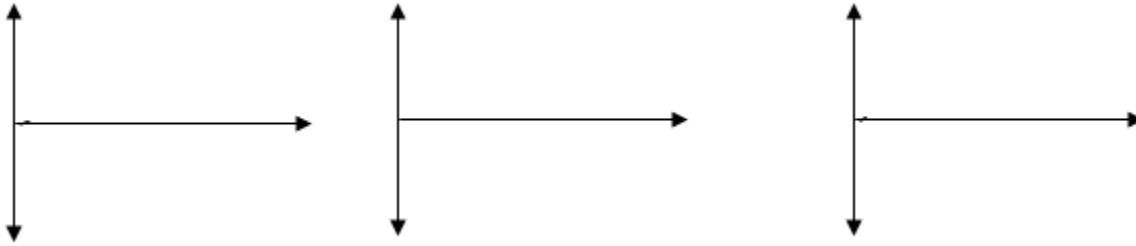

38. Draw the variation of susceptance with frequency in parallel resonance circuit

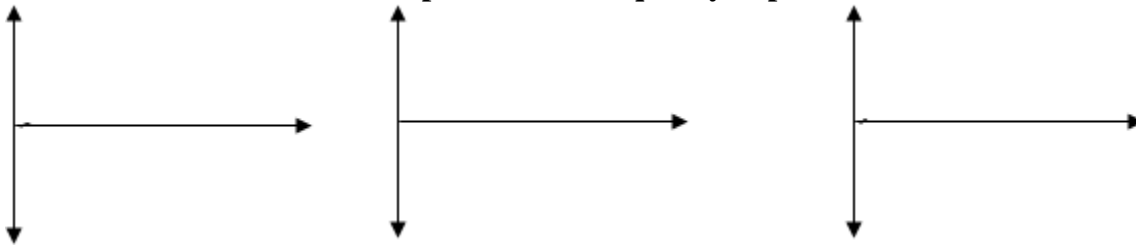

39. A series RLC circuit has a bandwidth of 500HZ. The quality factor is 15. If the value of L is 0.02. Find the value of C.

$$f_0 = \frac{1}{2\pi\sqrt{LC}}$$

$$f_0 = \text{Band width} \times \text{Quality factor}$$

$$= 500 \times 15 = 7500 \text{HZ}$$

$$C = \frac{1}{4\pi^2 \times 7500^2 \times 0.02}$$

$$= 5 \mu\text{f}$$

UNIT – V
ANALYSING THREE PHASE CIRCUITS

Three phases balanced / unbalanced voltage sources - Analysis of three phase 3-wire and 4-wire circuits with star and delta connected loads, balanced & unbalanced - Phasor diagram of voltages and currents - Power and power factor measurements in three phase circuits.

5.1 introduction:

- a. For household applications, we use single phase AC supply. But industries or big consumers are consuming large amount of power.
- b. Single phase supply is not sufficient for producing large amount of power.
- c. The large amount of power can be obtained from three phase AC supply.

d. Advantages of Three phase Supply:

- a. Most of the electric power is generated and distributed in three-phase.
1. The instantaneous power in a three-phase system can be constant.
 2. The amount of power, the three-phase system is more economical than the single-phase.
 - b. In fact, the amount of wire required for a three-phase system is less than that required for an equivalent single-phase system
 - c. Three phase induction motors are self starting unlike single phase induction motors.
 - d. Three phase machines have better power factor and efficiency.
 - e. For the same size, the capacity of a three phase machine is higher.

5.2 Phasor diagram of three phase supply:

Star Connection:

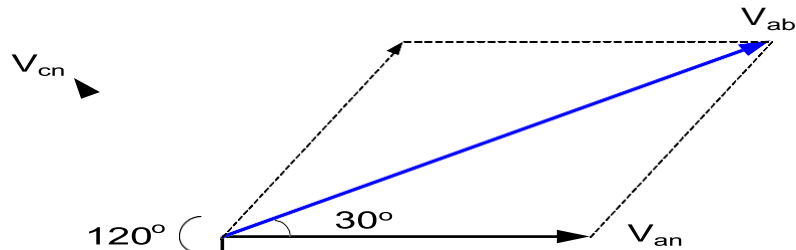

Delta Connection:

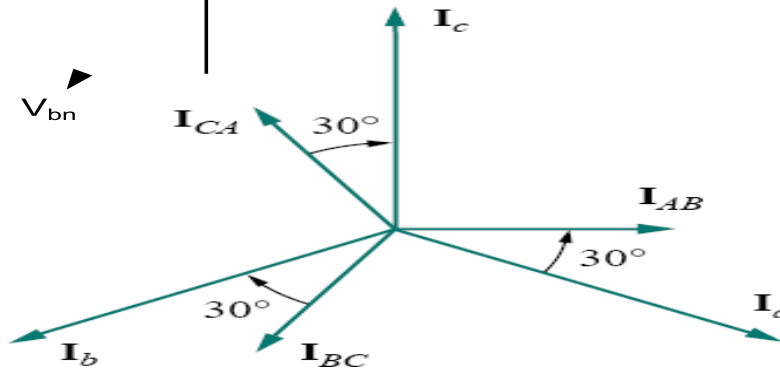

1. Connection of Three phases supply:

5.3.1 Star connection:

- a. The terminals R, Y and B are connected together to form the star point, also called the neutral (N).
- b. The lines R, Y and B are connected to the load. If the neutral is connected to the neutral of the load.

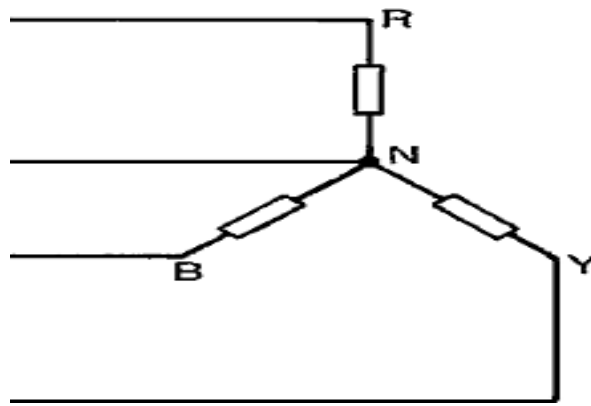

c. Line Voltage:

i. The voltage between the any two lines is called line voltage.

1. Phase Voltage:

a. The voltage between the line and neutral point is called phase voltage.

Relation between the line voltage and phase voltage:

$$V_L = \sqrt{3} V_p$$

➤ **Line current:**

○ The current through the line is called line current.

➤ **Phase current:**

○ The current through in any phase winding is called Phase current.

Relation between the line current and phase current:

$$I_L = I_{PH}$$

i. Delta Connection:

1) The end of the one winding R is connected to the start of the next phase winding Y. this connection form delta or mesh connection.

Relation between the line voltage and phase voltage:

$$V_L = V_{PH}$$

Relation between the line current and phase current:

$$I_L = I_p \sqrt{3}$$

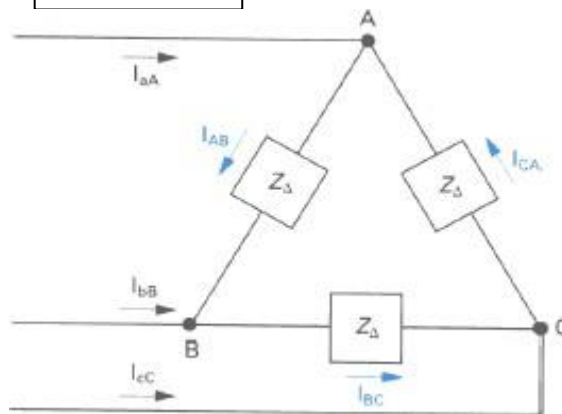

ii. Comparison of star and delta connection:

- ✓ Loads connected in delta dissipate three times more power than when connected in star to the same supply.
- ✓ For the same power, the phase currents must be the same for both delta and star connections (since power = 3 I² R_p), hence the line current in the delta connected system is greater than the line current in the corresponding star-connected system.

- ✓ To achieve the same phase current in a star-connected system as in a delta-connected system, the line voltage in the star system is $\sqrt{3}$ times the line voltage in the delta system.
- ✓ Thus for a given power transfer, a delta system is associated with larger line currents (and thus larger conductor cross sectional area) and a star system is associated with a larger line voltage (and thus greater insulation).

b. Three phase balanced and unbalanced voltage sources:

i. Balanced Voltage Sources:

- 5) If the voltage source have the same amplitude and frequency ω and are out of phase with each other by 120° , the voltage are said to be balanced

ii. Unbalanced Voltage Sources:

- 6) If the voltage source have the different amplitude and frequency ω and are out of phase with each other by 120° , the voltage are said to be balanced

iii. Balanced load:

- 7) A **balanced load** is one in which the phase impedances are equal in magnitude and in phase

iv. Unbalanced load:

- 8) An **unbalanced load** is one in which the phase impedances are different in magnitude and phases.

1. Types of Unbalanced load:

- 9) Unbalanced 3 wire star connected load
- 10) Unbalanced 4 wire star connected load
- 11) Unbalanced 3 wire delta connected load

b. Analysis of 3phase 3 wire with star & delta connected loads:

i. Star Connected load:

Consider a Y-connected load. We will derive the relationships of voltage, current and power for this connection.

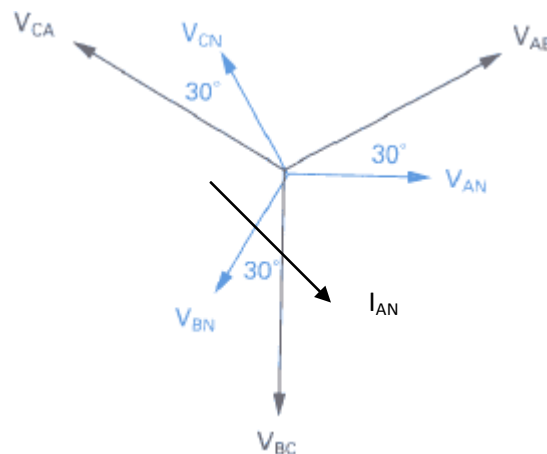
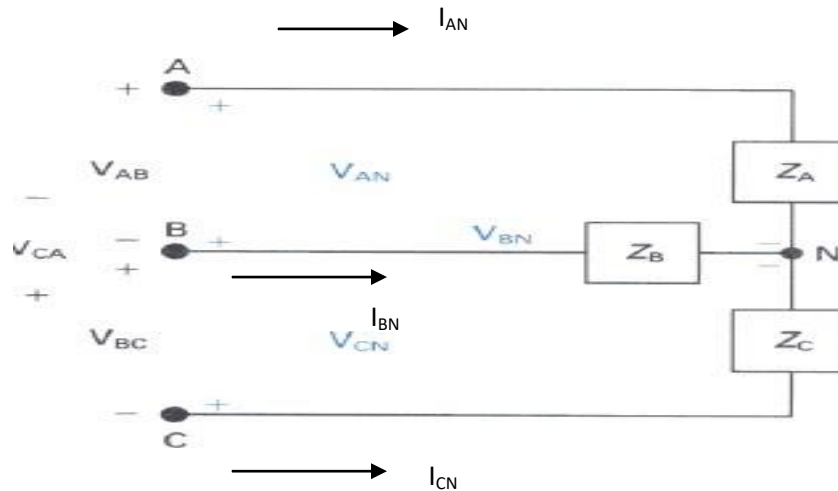

Fig. Three phase Y-connection and phasor diagram

Assume that we are given the phase voltages (sequence ABC):

$$V_{AN} = V_{\phi} \angle 0^{\circ}; \quad V_{\phi} \text{ is the magnitude of phase voltage}$$

$$V_{BN} = V_{\phi} \angle -120^{\circ}$$

$$V_{cN} = V_{\phi} \angle 120^{\circ}$$

We want to find the line voltages V_{AB} , V_{BC} and V_{CA} .

Using KVL,

$$\begin{aligned} V_{AB} &= V_{AN} + V_{NB} \\ &= V_{AN} - V_{BN} \\ &= V_{\phi} \angle 0^{\circ} + V_{\phi} \angle 60^{\circ} \\ &= \sqrt{3} V_{\phi} \angle 30^{\circ} \end{aligned}$$

This can be seen in the phasor diagram.

Similarly, you can find the other line voltages as,

$$V_{BC} = V_{BN} - V_{CN} = V_{\phi} \angle -120^{\circ} - V_{\phi} \angle 120^{\circ} = \sqrt{3} V_{\phi} \angle -90^{\circ}$$

$$V_{CA} = V_{CN} - V_{AN} = V_{\phi} \angle 120^{\circ} - V_{\phi} \angle 0^{\circ} = \sqrt{3} V_{\phi} \angle 150^{\circ}$$

See the phasor diagram above.

For the Y-connected three phase system, we observe that:

16. Line voltage $= \sqrt{3}$ Phase Voltage

17. Line current, $I_L =$ Phase current, I_{ϕ}

18. Line voltage V_{AB} is ahead of phase voltage V_{AN} by 30°

19. Total power, $P_T = 3$ Power per phase

$$= 3(V_{\phi} I_{\phi} \cos\theta)$$

$$= \sqrt{3} V_L I_L \cos\theta$$

20. Similarly, total reactive power $Q_T = \sqrt{3} V_L I_L \sin\theta$

21. The apparent power (or VA) $= |S| = \sqrt{P_T^2 + Q_T^2} = \sqrt{3} V_L I_L$

Note: The power factor angle θ is the angle between phase voltage V_{AN} and phase current I_{AN} .

5.5.2. Delta connected load:

Consider now a Δ -connected load. The circuit connection and phasor diagram showing the voltages and currents for the balanced circuit is shown below.

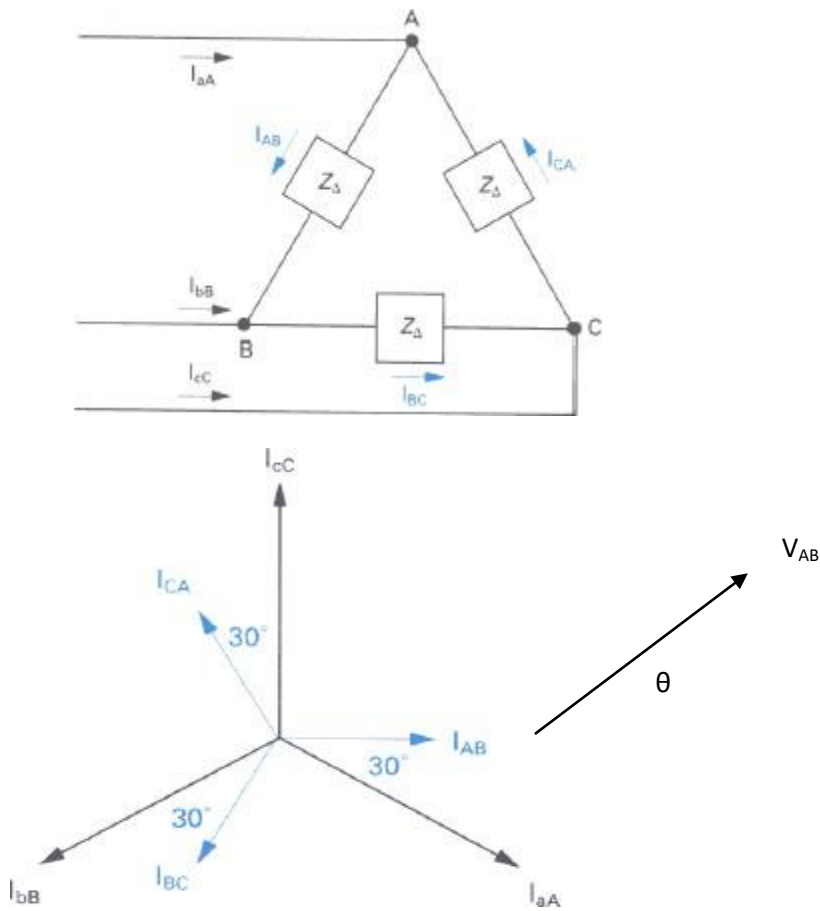

Fig. A Δ -connected load

We assume the phase currents, $I_{AB} = I_{\phi} \angle 0^{\circ}$, $I_{BC} = I_{\phi} \angle -120^{\circ}$, $I_{CA} = I_{\phi} \angle 120^{\circ}$

Applying KCL, the line currents are found as,

$$I_{aA} = I_{AB} - I_{CA} = \sqrt{3}I_{\phi} \angle -30^{\circ}$$

Similarly,

$$I_{bB} = \sqrt{3}I_{\phi} \angle -150^{\circ}, I_{cC} = \sqrt{3}I_{\phi} \angle 90^{\circ}$$

For the Δ -connected three phase system, we observe that

13. Line current = $\sqrt{3}$ Phase current, I_{ϕ}
14. Line voltage = Phase voltage
15. Line current I_{aA} is behind phase current I_{AB} by 30°

1) Total power, $P_T = 3$ Power per phase
 $= 3(V_{\phi} I_{\phi} \cos\theta)$
 $= \sqrt{3} V_L I_L \cos\theta$

13. Similarly, total reactive power $Q_T = \sqrt{3} V_L I_L \sin\theta$

14. The apparent power (or VA) = $|S| = \sqrt{P_T^2 + Q_T^2} = \sqrt{3} V_L I_L$

Note again: The power factor angle θ is the angle between phase voltage V_{AB} and phase current I_{AB} .

c. Measurements of power & power factor in 3phase circuits:

i. Measurement of power using single wattmeter:

Apparent power:

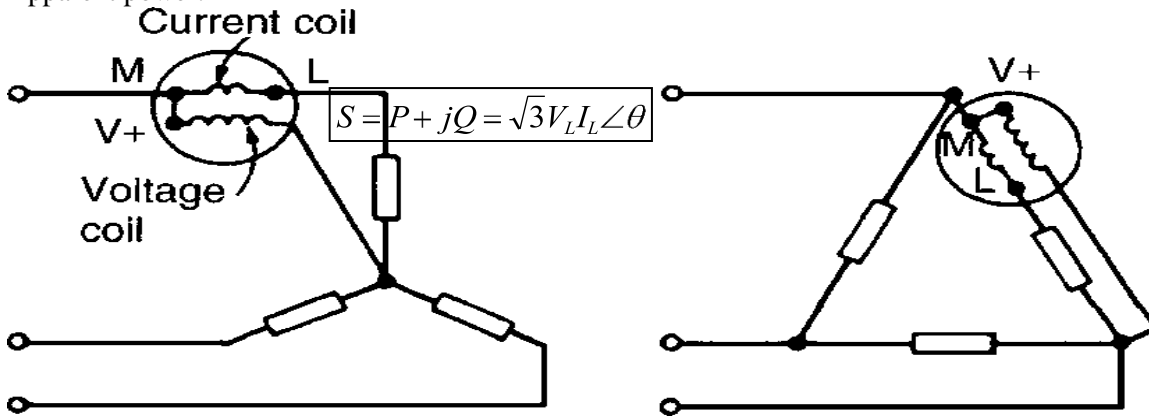

Real power:

$$P = 3P_p = 3V_p I_p \cos\theta = \sqrt{3}V_L I_L \cos\theta$$

$$\theta = \sqrt{\quad}$$

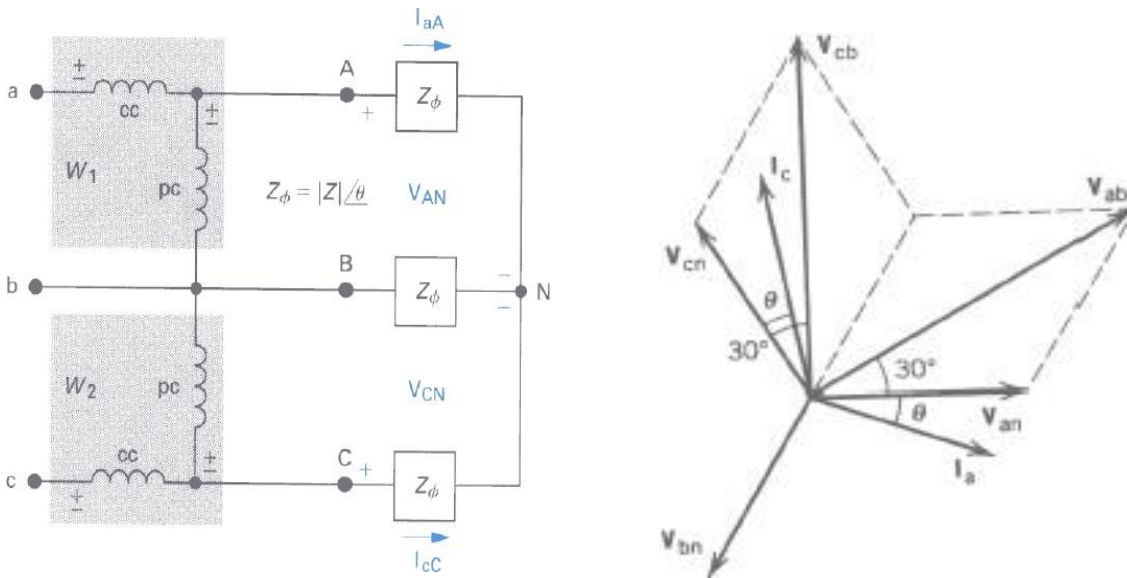

Fig. Two-wattmeter method- connection diagram and phasor diagram

The watt-meter readings are given by,

$$\begin{aligned} W_1 &= V_{ab} I_a \cos \angle(V_{ab}, I_a) \\ &= V_L I_L \cos(30^\circ + \theta) \end{aligned}$$

(1)

$$\begin{aligned} W_2 &= V_{cb} I_c \cos \angle(V_{cb}, I_c) \\ &= V_L I_L \cos(30^\circ - \theta) \end{aligned}$$

(2)

The sum of the two watt-meter readings gives the total three phase power,

$$\begin{aligned} P_T &= W_1 + W_2 = V_L I_L [\cos(30^\circ + \theta) + \cos(30^\circ - \theta)] \\ &= \sqrt{3} V_L I_L \end{aligned} \quad (3)$$

The difference of the two watt-meter readings is

$$\begin{aligned} W_2 - W_1 &= V_L I_L [\cos(30^\circ - \theta) + \cos(30^\circ + \theta)] \\ &= V_L I_L \sin \theta \end{aligned} \quad (4)$$

The total reactive power is, then,

$$Q_T = \sqrt{3}(W_2 - W_1) \quad (5)$$

The power factor angle can also be found from,

$$\theta = \tan^{-1}\left(\frac{Q_T}{P_T}\right) = \tan^{-1}\left[\frac{\sqrt{3}(W_2 - W_1)}{W_2 + W_1}\right] \quad (6)$$

Note:

When $\theta=0^\circ$	power factor=1	$W_1=W_2$ [From eq. (1) and (2)]
$\theta=60^\circ$	pf=0.5	$W_1=0, W_2>0$ ~
$\theta=90^\circ$	pf=0	$W_1=-W_2$ ~

For $60^\circ \leq \theta \leq 90^\circ$, one of the watt-meters will give negative readings. In the laboratory, when you have made the proper watt-meter connections, you will observe that one of the watt-meters is trying to read backwards. After switching the power supply off, reverse the connection of the voltage coil or the current coil (not both). The meter will now read upscale. Assign a negative sign to this reading.

Advantages of Two wattmeter method:

1. The method is applicable for balanced as well as unbalanced loads.
2. Only two wattmeter sufficient to measure total 3 phase power.
3. If the load is balanced not only the power but power factor also can be determined.

Disadvantages:

1. Not applicable for 3 phases, 4 wire system.
2. The sign of w_1 & w_2 must be identified and noted down correctly otherwise it may lead to the wrong result.

Problems

1. The input power to a 3-phase a.c. motor is measured as 5kW. If the voltage and current to the motor are 400V and 8.6A respectively, determine the power factor of the system?

Power $P=5000\text{W}$,
 line voltage $V_L = 400\text{ V}$,
 line current, $I_L = 8.6\text{A}$ and
 power, $P = \sqrt{3} V_L I_L \cos \phi$
 Hence
power factor $= \cos \phi = \frac{P}{\sqrt{3} V_L I_L}$
 $= \frac{5000}{\sqrt{3} (400) (8.6)}$
 $= \mathbf{0.839}$

2. Two wattmeters are connected to measure the input power to a balanced 3-phase load by the two-wattmeter method. If the instrument readings are 8kW and 4kW, determine (a) the total power input and (b) the load power factor. (MAY-08)

(a) Total input power,
 $P = P_1 + P_2 = 8 + 4 = \mathbf{12\text{kW}}$
 (b) $\tan \phi = \frac{\sqrt{3}(P_1 - P_2)}{(P_1 + P_2)}$
 $= \frac{\sqrt{3}(8 - 4)}{(8 + 4)}$
 $= \frac{\sqrt{3}(4/12)}{1}$
 $= \frac{\sqrt{3}(1/3)}{1}$
 $= 1/\sqrt{3}$

Hence $\phi = \tan^{-1} \frac{1}{\sqrt{3}} = 30^\circ$
 Power factor $= \cos \phi = \cos 30^\circ = \mathbf{0.866}$

3. Two wattmeters connected to a 3-phase motor indicate the total power input to be 12kW. The power factor is 0.6. Determine the readings of each wattmeter. (MAY-09)

If the two wattmeters indicate P_1 and P_2 respectively
 Then $P_1 + P_2 = 12\text{kW}$ ---(1)

$$\tan \phi = \frac{\sqrt{3}(P_1 - P_2)}{(P_1 + P_2)}$$

And power factor $= 0.6 = \cos \phi$.
 Angle $\phi = \cos^{-1} 0.6 = 53.13^\circ$ and
 $\tan 53.13^\circ = 1.3333$.

Hence

$$1.3333 = \frac{\sqrt{3}(P_1 - P_2)}{12}$$

From which,

$$P_1 - P_2 = \frac{12(1.3333)}{\sqrt{3}}$$

i.e. $P_1 - P_2 = 9.237\text{kW}$ -----(2)

Adding Equations (1) and (2) gives:

$$2P_1 = 21.237$$

i.e. $P_1 = \frac{21.237}{2}$
 $= 10.62\text{kW}$

Hence wattmeter 1 reads 10.62kW

From Equation (1), wattmeter 2 reads

$$(12 - 10.62) = 1.38\text{kW}$$

4. Three loads, each of resistance 30, are connected in star to a 415 V, 3-phase supply. Determine (a) the system phase voltage, (b) the phase current and (c) the line current. (MAY-09)

A '415 V, 3-phase supply' means that 415 V is the line voltage, V_L

(a) For a star connection, $V_L = \sqrt{3}V_p$

$$\begin{aligned} \text{Hence phase voltage, } V_p &= V_L / \sqrt{3} \\ &= 415 / \sqrt{3} \\ &= \mathbf{239.6 \text{ V or } 240 \text{ V}} \end{aligned}$$

correct to 3 significant figures

$$\begin{aligned} \text{(b) Phase current, } I_p &= V_p / R_p \\ &= 240 / 30 \\ &= \mathbf{8 \text{ A}} \end{aligned}$$

(c) For a star connection, $I_p = I_L$
Hence the line current, $I_L = \mathbf{8 \text{ A}}$

5. Three identical coils, each of resistance 10ohm and inductance 42mH are connected (a) in star and (b) in delta to a 415V, 50 Hz, 3-phase supply. Determine the total power dissipated in each case.

(a) Star connection

Inductive reactance,

$$X_L = 2\pi fL = 2\pi (50) (42 \times 10^{-3}) = 13.19$$

Phase impedance,

$$\begin{aligned} Z_p &= \sqrt{R^2 + X_L^2} \\ &= \sqrt{10^2 + 13.19^2} = 16.55 \end{aligned}$$

Line voltage,

$$V_L = 415 \text{ V}$$

And phase voltage,

$$V_p = V_L / \sqrt{3} = 415 / \sqrt{3} = 240 \text{ V.}$$

Phase current,

$$I_p = V_p / Z_p = 240 / 16.55 = 14.50 \text{ A.}$$

Line current,

$$I_L = I_p = 14.50 \text{ A.}$$

$$\begin{aligned} \text{Power factor} &= \cos \phi = R_p / Z_p = 10 / 16.55 \\ &= 0.6042 \text{ lagging.} \end{aligned}$$

Power dissipated,

$$P = \sqrt{3} V_L I_L \cos \phi = \sqrt{3} (415) (14.50) (0.6042) = \mathbf{6.3 \text{ kW}}$$

(Alternatively,

$$P = 3I^2R = 3(14.50)^2(10) = \mathbf{6.3 \text{ kW}})$$

(b) Delta connection

$$V_L = V_p = 415 \text{ V,}$$

$$Z_p = 16.55 _, \cos \phi = 0.6042$$

lagging (from above).

Phase current,

$$I_p = V_p / Z_p = 415 / 16.55 = 25.08 \text{ A.}$$

Line current,

$$I_L = \sqrt{3}I_p = \sqrt{3}(25.08) = 43.44 \text{ A.}$$

Power dissipated,

$$\begin{aligned} P &= \sqrt{3} V_L I_L \cos \phi \\ &= \sqrt{3} (415) (43.44) (0.6042) = \mathbf{18.87 \text{ kW}} \end{aligned}$$

(Alternatively,

$$\begin{aligned} P &= 3I^2R \\ &= 3(25.08)^2(10) = \mathbf{18.87 \text{ kW}} \end{aligned}$$

6. A 415V, 3-phase a.c. motor has a power output of 12.75kW and operates at a power factor of 0.77 lagging and with an efficiency of 85 per cent. If the motor is delta-connected, determine (a) the power input, (b) the line current and (c) the phase current.

(a) Efficiency = power output / power input.

Hence

$$(85/100) = 12.750 \text{ power input from which,}$$

$$\text{Power input} = 12.750 \times 100/85 \\ = \mathbf{15\,000W \text{ or } 15Kw}$$

(b) Power, $P = \sqrt{3} V_L I_L \cos \phi$, hence

(c) **line current,**

$$I_L = P / \sqrt{3} (415) (0.77) \\ = 15\,000 / \sqrt{3} (415) (0.77) \\ = \mathbf{27.10A}$$

(d) For a delta connection, $I_L = \sqrt{3} I_p$,

Hence

$$\text{Phase current, } I_p = I_L / \sqrt{3} \\ = 27.10 / \sqrt{3} \\ = \mathbf{15.65A}$$

7. A 400V, 3-phase star connected alternator supplies a delta-connected load, each phase of which has a resistance of 30_ and inductive reactance 40_. Calculate (a) the current supplied by the alternator and (b) the output power and the kVA of the alternator, neglecting losses in the line between the alternator and load.

A circuit diagram of the alternator and load is shown in Fig.

(a) Considering the load:

$$\text{Phase current, } I_p = V_p / Z_p$$

$$V_p = V_L \text{ for a delta connection,}$$

$$\text{Hence } V_p = 400V.$$

Phase impedance,

$$Z_p = \sqrt{(R^2 + X_L^2)} \\ = \sqrt{(30^2 + 40^2)} = 50$$

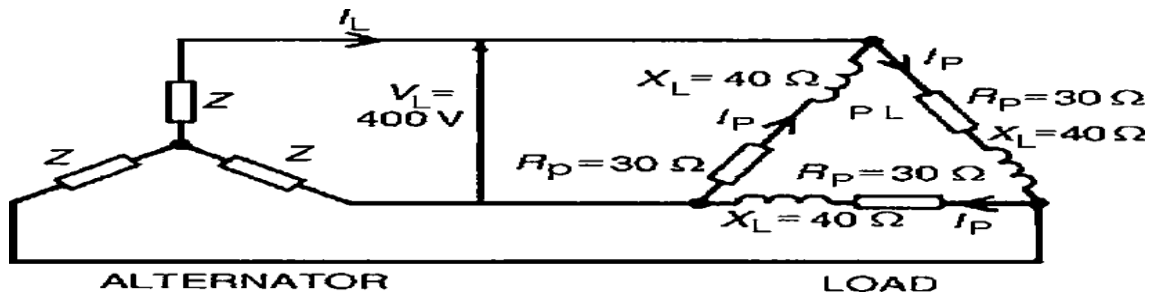

Figure

Hence $I_p = V_p/Z_p = 400/50 = 8A$.

For a delta-connection,

Line current, $I_L = \sqrt{3} I_p = \sqrt{3} (8) = 13.86 A$.

Hence **13.86A is the current supplied by the alternator.**

(b) Alternator output power is equal to the power
Dissipated by the load

I.e. $P = \sqrt{3} V_L I_L \cos \phi$,

Where $\cos \phi = R_p/Z_p = 30/50 = 0.6$.

$$\begin{aligned} \text{Hence } P &= \sqrt{3} (400) (13.86) (0.6) \\ &= \mathbf{5.76kW}. \end{aligned}$$

Alternator output kVA,

$$\begin{aligned} S &= \sqrt{3} V_L I_L = \sqrt{3} (400) (13.86) \\ &= \mathbf{9.60 kVA}. \end{aligned}$$

QUESTION BANK

PART-A

TWO MARKS

1. What are the Advantages of 3 phase system?[DEC-10]

- Most of the electric power is generated and distributed in three-phase.
- The instantaneous power in a three-phase system can be constant.
- The amount of power, the three-phase system is more economical than the single-phase.
- In fact, the amount of wire required for a three-phase system is less than that required for an equivalent single-phase system.

2. Define phase, line & neutral?

Phase

Describes or pertains to one element or device in a load, line, or source. It is simply a "branch" of the circuit and could look something like this.

Line

refers to the "transmission line" or wires that connect the source (supply) to the load. It may be modeled as a small impedance (actually 3 of them), or even by just a connecting line.

Neutral

the 4th wire in the 3-phase system. It's where the phases of a Y connection come together.

3. Define Phase Voltages & Phase Currents?

Phase Voltages & Phase Currents

the voltages and currents across and through a single branch (phase) of the circuit. Note this definition depends on whether the connection is Wye or Delta!

4. Define line voltage and line current?

Line Currents

the currents flowing in each of the lines (I_a , I_b , and I_c). This definition does not change with connection type.

Line Voltages

the voltages between any two of the lines (V_{ab} , V_{bc} , and V_{ca}). These may also be referred to as the line-to-line voltages. This definition does not change with connection type.

5. Define line to neutral voltages and line to neutral current?

Line to Neutral Voltages

the voltages between any lines and the neutral point (V_a , V_b , and V_c). This definition does not change with connection type, but they may not be physically measurable in a Delta circuit.

Line to Neutral Currents

same as the line currents (I_a , I_b , and I_c).

6. Write the relationship of line and phase voltage and current in star?

$$I_L = I_{PH}$$

$$V_L = \sqrt{3} V_p$$

7. Write the relationship of line and phase voltage and current in delta?

$$V_L = V_{PH}$$

$$I_L = I_p \sqrt{3}$$

8. Draw the phasor diagram of delta connection? (JUN-09)

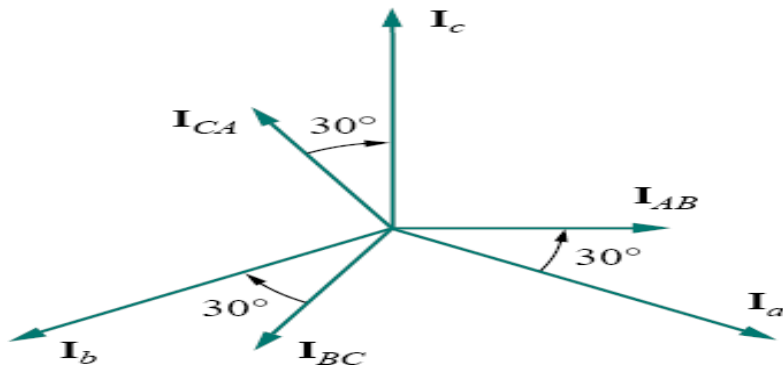

9. Define balanced load?

If the voltage source have the same amplitude and frequency ω and are out of phase with each other by 120° , the voltage are said to be balanced.

A *balanced load* is one in which the phase impedances are equal in magnitude and in phase

10. Define unbalanced load? (JUN-09)[DEC-10]

The load in which the load impedance are not same but having different values. The value of voltage and current are different in each phase.

11. Types of unbalanced load? (JUN-09)

- a. Unbalanced 3 wire star connected load
- b. Unbalanced 4 wire star connected load
- c. Unbalanced 3 wire delta connected load.

12. Write 3 phase power equation?

Apparent power:

$$S = P + jQ = \sqrt{3}V_L I_L \angle \theta$$

True power:

$$P = 3P_p = 3V_p I_p \cos \theta = \sqrt{3}V_L I_L \cos \theta$$

Reactive power:

$$Q = 3Q_p = 3V_p I_p \sin \theta = \sqrt{3}V_L I_L \sin \theta$$

17. Write the power factor calculation of two wattmeter method? (JUN-09)

$$\cos \theta = \frac{P_T}{\sqrt{3(W_2 - W_1)}} = \tan^{-1} \left[\frac{\sqrt{3}(W_2 - W_1)}{W_2 + W_1} \right]$$

1. Draw two wattmeter methods for measurement of power in 3 phase systems?

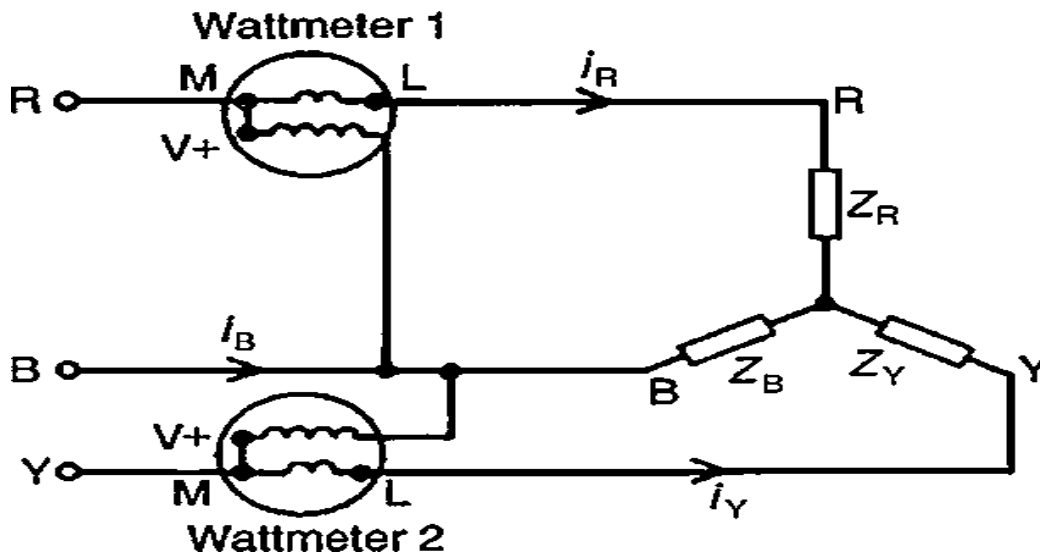

2. Comparisons of star and delta connections?

4. Loads connected in delta dissipate three times more power than when connected in star to the same supply.
5. For the same power, the phase currents must be the same for both delta and star connections (since $\text{power} = 3I^2 R_p$), hence the line current in the delta connected system is greater than the line current in the corresponding star-connected system.
6. To achieve the same phase current in a star-connected system as in a delta-connected system, the line voltage in the star system is $\sqrt{3}$ times the line voltage in the delta system.
7. Thus for a given power transfer, a delta system is associated with larger line currents (and thus larger conductor cross sectional area) and a star system is associated with a larger line voltage (and thus greater insulation).

3. Three loads, each of resistance 30 Ω , are connected in star to a 415 V, 3-phase supply. Determine (a) the system phase voltage, (b) the phase current and (c) the line current. (MAY-09)

A '415 V, 3-phase supply' means that 415 V is the line voltage, V_L

(a) For a star connection, $V_L = \sqrt{3} V_p$

$$\begin{aligned} \text{Hence phase voltage, } V_p &= V_L / \sqrt{3} \\ &= 415 / \sqrt{3} \\ &= \mathbf{239.6 \text{ V or } 240 \text{ V}} \end{aligned}$$

correct to 3 significant figures

$$\begin{aligned} \text{(b) Phase current, } I_p &= V_p / R_p \\ &= 240 / 30 \\ &= \mathbf{8 \text{ A}} \end{aligned}$$

(c) For a star connection, $I_p = I_L$

Hence the line current, $I_L = \mathbf{8 \text{ A}}$

PART-B

16 MARKS

1. A Three phase delta connected load has $Z_{ab} = (100+j0) \text{ ohm}$, $Z_{bc} = (-j100) \text{ ohm}$ and $Z_{ca} = (70.7+j70.7) \text{ ohm}$ is connected to a balanced 3 phase 400V supply. Determine the line currents I_a , I_b and I_c . (JAN-09)
2. Prove how 3 phase can be measured using two wattmeters (JAN-09,07)
3. A 3phase balanced delta connected load of $4.3+j7$ connected across a 400V 3 phase balanced supply. Determine I_{ph} , I_L and P, Q, S, p.f. (JAN-09)

COMPLEX NUMBER

The mathematics used in Electrical Engineering to add together resistances, currents or DC voltages use what are called “real numbers” used as either integers or as fractions.

- Click to share on Twitter (Opens in new window)
- Click to share on Facebook (Opens in new window)
- Click to share on LinkedIn (Opens in new window)
-

But real numbers are not the only kind of numbers we need to use especially when dealing with frequency dependent sinusoidal sources and vectors. As well as using normal or real numbers, **Complex Numbers** were introduced to allow complex equations to be solved with numbers that are the square roots of negative numbers, $\sqrt{-1}$.

In electrical engineering this type of number is called an “imaginary number” and to distinguish an imaginary number from a real number the letter “j” known commonly in electrical engineering as the **j-operator**, is used. Thus the letter “j” is placed in front of a real number to signify its imaginary number operation.

Examples of imaginary numbers are: j3, j12, j100 etc. Then a **complex number** consists of two distinct but very much related parts, a “Real Number” plus an “Imaginary Number”.

Complex Numbers represent points in a two dimensional complex or s-plane that are referenced to two distinct axes. The horizontal axis is called the “real axis” while the vertical axis is called the “imaginary axis”. The real and imaginary parts of a complex number are abbreviated as $\text{Re}(z)$ and $\text{Im}(z)$, respectively.

Complex numbers that are made up of real (the active component) and imaginary (the reactive component) numbers can be added, subtracted and used in exactly the same way as elementary algebra is used to analyse DC Circuits.

The rules and laws used in mathematics for the addition or subtraction of imaginary numbers are the same as for real numbers, $j2 + j4 = j6$ etc. The only difference is in multiplication because two imaginary numbers multiplied together becomes a negative real number. Real numbers can also be thought of as a complex number but with a zero imaginary part labelled j0.

The j-operator has a value exactly equal to $\sqrt{-1}$, so successive multiplication of “j”, ($j \times j$) will result in j having the following values of, -1, -j and +1. As the j-operator is commonly used to indicate the anticlockwise rotation of a vector, each successive multiplication or power of “j”, j^2, j^3 etc, will force the vector to rotate through a fixed angle of 90° in an anticlockwise direction as shown below. Likewise, if the multiplication of the vector results in a -j operator then the phase shift will be -90°, i.e. a clockwise rotation.

Vector Rotation of the j-operator

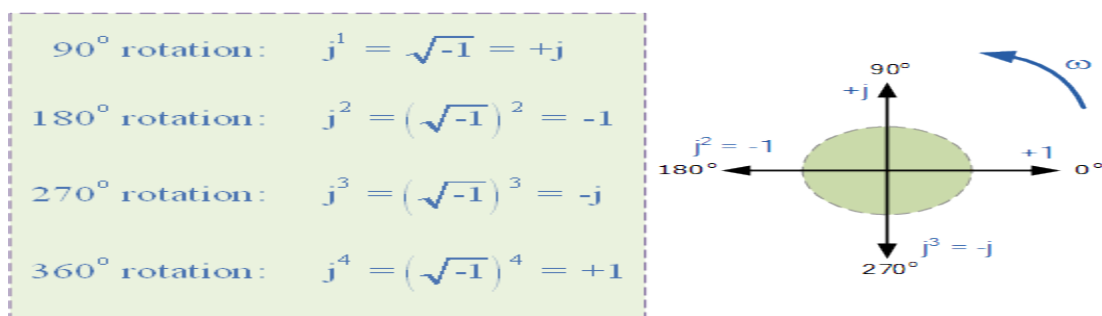

So by multiplying an imaginary number by j^2 will rotate the vector by 180° anticlockwise, multiplying by j^3 rotates it 270° and by j^4 rotates it 360° or back to its original position. Multiplication by j^{10} or by j^{30} will cause the vector to rotate anticlockwise by the appropriate amount. In each successive rotation, the magnitude of the vector always remains the same.

In Electrical Engineering there are different ways to represent a complex number either graphically or mathematically. One such way that uses the cosine and sine rule is called the Cartesian or Rectangular Form.

Complex Numbers using the Rectangular Form

In the last tutorial about Phasors, we saw that a complex number is represented by a real part and an imaginary part that takes the generalised form of:

$$Z = x + jy$$

- Where:
- Z – is the Complex Number representing the Vector
- x – is the Real part or the Active component
- y – is the Imaginary part or the Reactive component
- j – is defined by $\sqrt{-1}$

In the rectangular form, a complex number can be represented as a point on a two dimensional plane called the complex or s-plane. So for example, $Z = 6 + j4$ represents a single point whose coordinates represent 6 on the horizontal real axis and 4 on the vertical imaginary axis as shown.

Complex Numbers using the Complex or s-plane

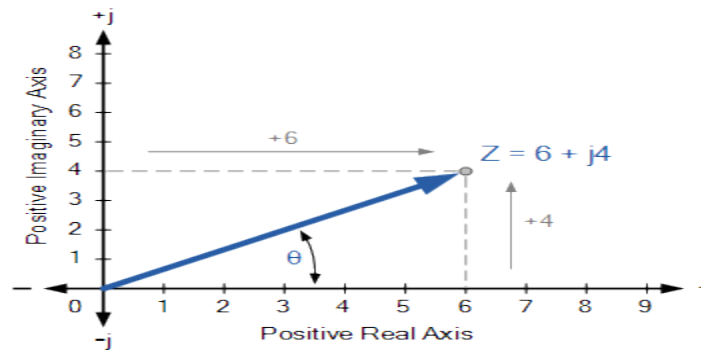

But as both the real and imaginary parts of a complex number in the rectangular form can be either a positive number or a negative number, then both the real and imaginary axis must also extend in both the positive and negative directions. This then produces a complex plane with four quadrants called an Argand Diagram as shown below.

Four Quadrant Argand Diagram

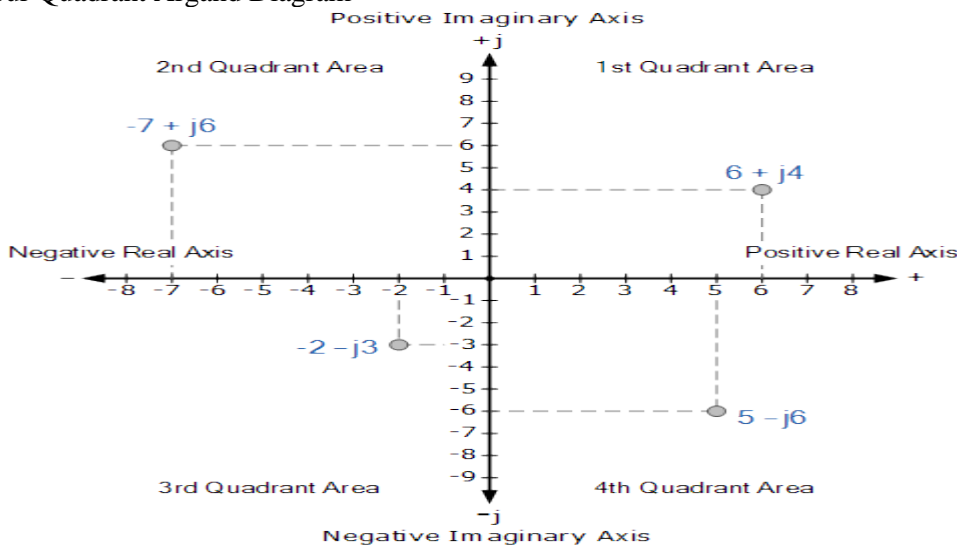

On the Argand diagram, the horizontal axis represents all positive real numbers to the right of the vertical imaginary axis and all negative real numbers to the left of the vertical imaginary axis. All positive imaginary numbers are represented above the horizontal axis while all the negative imaginary numbers are below the horizontal real axis. This then produces a two dimensional complex plane with four distinct quadrants labelled, QI, QII, QIII, and QIV.

The Argand diagram above can also be used to represent a rotating phasor as a point in the complex plane whose radius is given by the magnitude of the phasor will draw a full circle around it for every $2\pi/\omega$ seconds.

Then we can extend this idea further to show the definition of a complex number in both the polar and rectangular form for rotations of 90° .

$$\begin{aligned}
 0^\circ &= \pm 360^\circ = +1 = 1 \angle 0^\circ = 1 + j0 \\
 +90^\circ &= +\sqrt{-1} = +j = 1 \angle +90^\circ = 0 + j1 \\
 -90^\circ &= -\sqrt{-1} = -j = 1 \angle -90^\circ = 0 - j1 \\
 \pm 180^\circ &= (\sqrt{-1})^2 = -1 = 1 \angle \pm 180^\circ = -1 + j0
 \end{aligned}$$

Complex Numbers can also have “zero” real or imaginary parts such as: $Z = 6 + j0$ or $Z = 0 + j4$. In this case the points are plotted directly onto the real or imaginary axis. Also, the angle of a complex number can be calculated using simple trigonometry to calculate the angles of right-angled triangles, or measured anti-clockwise around the Argand diagram starting from the positive real axis.

Then angles between 0 and 90° will be in the first quadrant (I), angles (θ) between 90 and 180° in the second quadrant (II). The third quadrant (III) includes angles between 180 and 270° while the fourth and final quadrant (IV) which completes the full circle, includes the angles between 270 and 360° and so on. In all the four quadrants the relevant angles can be found from:

$$\tan^{-1}(\text{imaginary component} \div \text{real component})$$

Addition and Subtraction of Complex Numbers

The addition or subtraction of complex numbers can be done either mathematically or graphically in rectangular form. For addition, the real parts are firstly added together to form the real part of the sum, and then the imaginary parts to form the imaginary part of the sum and this process is as follows using two complex numbers A and B as examples.

Complex Addition and Subtraction

$$A = x + jy \quad B = w + jz$$

$$A + B = (x + w) + j(y + z)$$

$$A - B = (x - w) + j(y - z)$$

Complex Numbers Example No1

Two vectors are defined as, $A = 4 + j1$ and $B = 2 + j3$ respectively. Determine the sum and difference of the two vectors in both rectangular ($a + jb$) form and graphically as an Argand Diagram.

Mathematical Addition and Subtraction

Addition

$$A + B = (4 + j1) + (2 + j3)$$

$$A + B = (4 + 2) + j(1 + 3) = 6 + j4$$

Subtraction

$$A - B = (4 + j1) - (2 + j3)$$

$$A - B = (4 - 2) + j(1 - 3) = 2 - j2$$

Graphical Addition and Subtraction

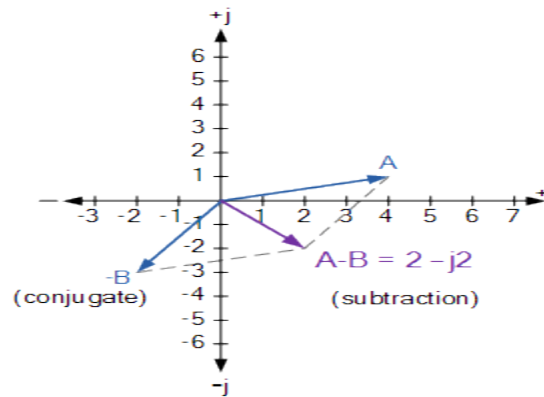
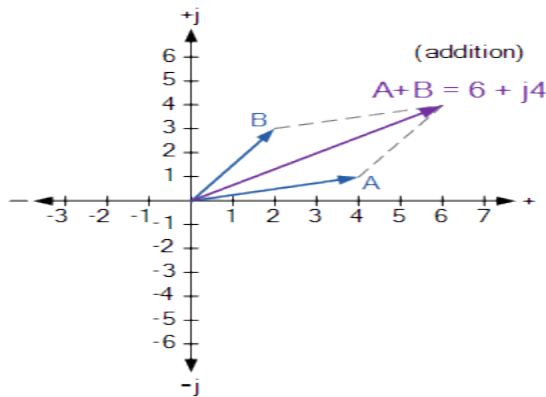

Multiplication and Division of Complex Numbers

The multiplication of complex numbers in the rectangular form follows more or less the same rules as for normal algebra along with some additional rules for the successive multiplication of the j -operator where: $j^2 = -1$. So for example, multiplying together our two vectors from above of $A = 4 + j1$ and $B = 2 + j3$ will give us the following result.

$$A \times B = (4 + j1)(2 + j3)$$

$$= 8 + j12 + j2 + j^2 3$$

$$\text{but } j^2 = -1,$$

$$= 8 + j14 - 3$$

$$A \times B = 5 + j14$$

Mathematically, the division of complex numbers in rectangular form is a little more difficult to perform as it requires the use of the denominators conjugate function to convert the denominator of the equation into a real number. This is

called “rationalising”. Then the division of complex numbers is best carried out using “Polar Form”, which we will look at later. However, as an example in rectangular form lets find the value of vector A divided by vector B.

$$\frac{A}{B} = \frac{4 + j1}{2 + j3}$$

Multiply top & bottom by Conjugate of $2 + j3$

$$\begin{aligned} \frac{4 + j1}{2 + j3} \times \frac{2 - j3}{2 - j3} &= \frac{8 - j12 + j2 - j^2 3}{4 - j6 + j6 - j^2 9} \\ &= \frac{8 - j10 + 3}{4 + 9} = \frac{11 - j10}{13} \\ &= \frac{11}{13} + \frac{-j10}{13} = 0.85 - j0.77 \end{aligned}$$

The Complex Conjugate

The **Complex Conjugate**, or simply **Conjugate** of a complex number is found by reversing the algebraic sign of the complex numbers imaginary number only while keeping the algebraic sign of the real number the same and to identify the complex conjugate of z the symbol z is used. For example, the conjugate of $z = 6 + j4$ is $z = 6 - j4$, likewise the conjugate of $z = 6 - j4$ is $z = 6 + j4$.

The points on the Argand diagram for a complex conjugate have the same horizontal position on the real axis as the original complex number, but opposite vertical positions. Thus, complex conjugates can be thought of as a reflection of a complex number. The following example shows a complex number, $6 + j4$ and its conjugate in the complex plane.

Conjugate Complex Numbers

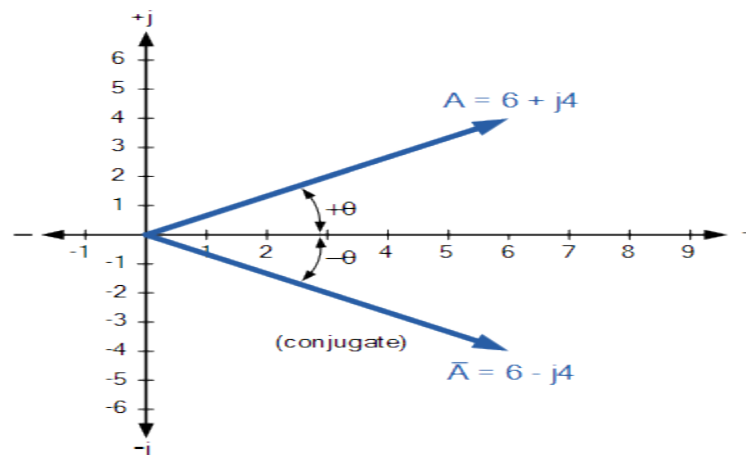

The sum of a complex number and its complex conjugate will always be a real number as we have seen above. Then the addition of a complex number and its conjugate gives the result as a real number or active component only, while their subtraction gives an imaginary number or reactive component only. The conjugate of a complex number is an important element used in Electrical Engineering to determine the apparent power of an AC circuit using rectangular form.

Complex Numbers using Polar Form

Unlike rectangular form which plots points in the complex plane, the **Polar Form** of a complex number is written in terms of its magnitude and angle. Thus, a polar form vector is presented as: $Z = A \angle \pm\theta$, where: Z is the complex number in polar form, A is the magnitude or modulo of the vector and θ is its angle or argument of A which can be either positive or negative. The magnitude and angle of the point still remains the same as for the rectangular form above, this time in polar form the location of the point is represented in a “triangular form” as shown below.

Polar Form Representation of a Complex Number

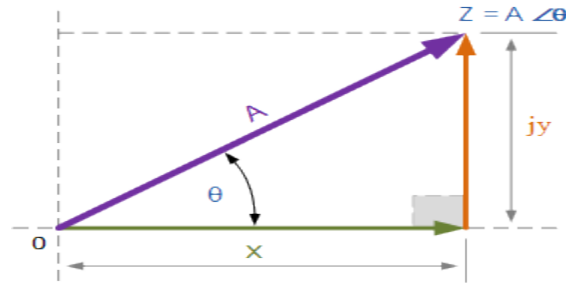

As the polar representation of a point is based around the triangular form, we can use simple geometry of the triangle and especially trigonometry and Pythagoras’s Theorem on triangles to find both the magnitude and the angle of the complex number. As we remember from school, trigonometry deals with the relationship between the sides and the angles of triangles so we can describe the relationships between the sides as:

$$A^2 = x^2 + y^2$$

$$A = \sqrt{x^2 + y^2}$$

$$\text{Also, } x = A \cdot \cos\theta, \quad y = A \cdot \sin\theta$$

Using trigonometry again, the angle θ of A is given as follows.

$$\theta = \tan^{-1} \frac{y}{x}$$

Then in Polar form the length of A and its angle represents the complex number instead of a point. Also in polar form, the conjugate of the complex number has the same magnitude or modulus it is the sign of the angle that changes, so for example the conjugate of $6 \angle 30^\circ$ would be $6 \angle -30^\circ$.

Converting between Rectangular Form and Polar Form

In the rectangular form we can express a vector in terms of its rectangular coordinates, with the horizontal axis being its real axis and the vertical axis being its imaginary axis or j -component. In polar form these real and imaginary axes are simply represented by “ $A \angle \theta$ ”. Then using our example above, the relationship between rectangular form and polar form can be defined as.

Converting Polar Form into Rectangular Form, (P→R)

$$6 \angle 30^\circ = x + jy$$

However,

$$x = A \cdot \cos\theta \quad y = A \cdot \sin\theta$$

Therefore,

$$\begin{aligned} 6 \angle 30^\circ &= (6 \cos\theta) + j(6 \sin\theta) \\ &= (6 \cos 30^\circ) + j(6 \sin 30^\circ) \\ &= (6 \times 0.866) + j(6 \times 0.5) \\ &= 5.2 + j3 \end{aligned}$$

We can also convert back from rectangular form to polar form as follows.

Converting Rectangular Form into Polar Form, (R→P)

$$(5.2 + j3) = A \angle \theta$$

$$\text{where: } A = \sqrt{5.2^2 + 3^2} = 6$$

$$\text{and } \theta = \tan^{-1} \frac{3}{5.2} = 30^\circ$$

$$\text{Hence, } (5.2 + j3) = 6 \angle 30^\circ$$

Polar Form Multiplication and Division

Rectangular form is best for adding and subtracting complex numbers as we saw above, but polar form is often better for multiplying and dividing. To multiply together two vectors in polar form, we must first multiply together the two modulus or magnitudes and then add together their angles.

Multiplication in Polar Form

$$Z_1 \times Z_2 = A_1 \times A_2 \angle \theta_1 + \theta_2$$

Multiplying together $6 \angle 30^\circ$ and $8 \angle -45^\circ$ in polar form gives us.

$$Z_1 \times Z_2 = 6 \times 8 \angle 30^\circ + (-45^\circ) = 48 \angle -15^\circ$$

Division in Polar Form

Likewise, to divide together two vectors in polar form, we must divide the two modulus and then subtract their angles as shown.

$$\frac{Z_1}{Z_2} = \left(\frac{A_1}{A_2} \right) \angle \theta_1 - \theta_2$$

$$\frac{Z_1}{Z_2} = \left(\frac{6}{8} \right) \angle 30^\circ - (-45^\circ) = 0.75 \angle 75^\circ$$

Fortunately today's modern scientific calculators have built in mathematical functions (check your book) that allows for the easy conversion of rectangular to polar form, (R → P) and back from polar to rectangular form, (R → P).

Complex Numbers using Exponential Form

So far we have considered complex numbers in the **Rectangular Form**, (a + jb) and the **Polar Form**, (A ∠ ±θ). But there is also a third method for representing a complex number which is similar to the polar form that corresponds to the length (magnitude) and phase angle of the sinusoid but uses the base of the natural logarithm, e = 2.718 281.. to find the value of the complex number. This third method is called the **Exponential Form**.

The **Exponential Form** uses the trigonometric functions of both the sine (sin) and the cosine (cos) values of a right angled triangle to define the complex exponential as a rotating point in the complex plane. The exponential form for finding the position of the point is based around Euler's Identity, named after Swiss mathematician, Leonhard Euler and is given as:

$$Z = Ae^{j\phi}$$

$$Z = A(\cos\phi + j\sin\phi)$$

Then Euler's identity can be represented by the following rotating phasor diagram in the complex plane.

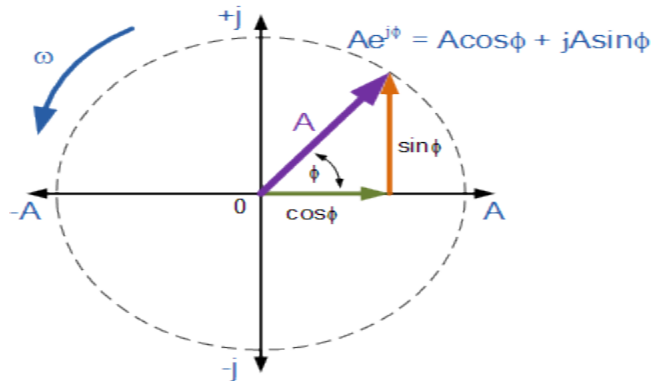

We can see that Euler's identity is very similar to the polar form above and that it shows us that a number such as $Ae^{j\theta}$ which has a magnitude of 1 is also a complex number. Not only can we convert complex numbers that are in exponential form easily into polar form such as: $2e^{j30} = 2\angle 30$, $10e^{j120} = 10\angle 120$ or $-6e^{j90} = -6\angle 90$, but Euler's identity also gives us a way of converting a complex number from its exponential form into its rectangular form. Then the relationship between, Exponential, Polar and Rectangular form in defining a complex number is given as.

Complex Number Forms

$$Z = x + jy = A\angle\theta = A(\cos\phi + j\sin\phi)$$

Phasor Notation

So far we have look at different ways to represent either a rotating vector or a stationary vector using complex numbers to define a point on the complex plane. Phasor notation is the process of constructing a single complex number that has the amplitude and the phase angle of the given sinusoidal waveform.

Then phasor notation or phasor transform as it is sometimes called, transfers the real part of the sinusoidal function: $A(t) = A_m \cos(\omega t \pm \Phi)$ from the time domain into the complex number domain which is also called the frequency domain. For example:

$$V_{(t)} = V_m \cos(\omega t + \theta) \quad \Leftrightarrow \quad \text{Euler's identity: } e^{\pm j\theta} = \cos\theta \pm j\sin\theta$$

$$V_{(t)} = 20 \cos(\omega t + 30^\circ) \text{ Volts} \Rightarrow \left(\frac{20}{\sqrt{2}} \right) \angle 30^\circ \Rightarrow V_{\text{RMS}} = 14.14 \angle 30^\circ$$

or

$$V_{(t)} = 35 \cos(\omega t + 45^\circ) \text{ Volts} \Rightarrow \left(\frac{35}{\sqrt{2}} \right) \angle 45^\circ \Rightarrow V_{\text{RMS}} = 24.75 \angle 45^\circ$$

or

$$V_{(t)} = 10 \cos(\omega t - 30^\circ) \text{ Volts} \Rightarrow \left(\frac{10}{\sqrt{2}} \right) \angle -30^\circ \Rightarrow V_{\text{RMS}} = 7.07 \angle -30^\circ$$

or

$$V_{(t)} = 100 \cos(\omega t) \text{ Volts} \Rightarrow \left(\frac{100}{\sqrt{2}} \right) \angle 0^\circ \Rightarrow V_{\text{RMS}} = 70.72 \angle 0^\circ$$

Please note that the $\sqrt{2}$ converts the maximum amplitude into an effective or RMS value with the phase angle given in radians, (ω).

Summary of Complex Numbers

Then to summarize this tutorial about **Complex Numbers** and the use of complex numbers in electrical engineering.

- Complex Numbers consist of two distinct numbers, a real number plus an imaginary number.
- Imaginary numbers are distinguish from a real number by the use of the j-operator.
- A number with the letter "j" in front of it identifies it as an imaginary number in the complex plane.
- By definition, the j-operator $j \equiv \sqrt{-1}$
- Imaginary numbers can be added, subtracted, multiplied and divided the same as real numbers.
- The multiplication of "j" by "j" gives $j^2 = -1$
- In Rectangular Form a complex number is represented by a point in space on the complex plane.
- In Polar Form a complex number is represented by a line whose length is the amplitude and by the phase angle.
- In Exponential Form a complex number is represented by a line and corresponding angle that uses the base of the natural logarithm.
- A complex number can be represented in one of three ways:
 - $Z = x + jy$ » Rectangular Form
 - $Z = A \angle \Phi$ » Polar Form
 - $Z = A e^{j\Phi}$ » Exponential Form
- Euler's identity can be used to convert Complex Numbers from exponential form into rectangular form.

In the previous tutorials including this one we have seen that we can use phasors to represent sinusoidal waveforms and that their amplitude and phase angle can be written in the form of a complex number. We have also seen that **Complex Numbers** can be presented in rectangular, polar or exponential form with the conversion between each complex number algebra form including addition, subtracting, multiplication and division.

In the next few tutorials relating to the phasor relationship in AC series circuits, we will look at the impedance of some common passive circuit components and draw the phasor diagrams for both the current flowing through the component and the voltage applied across it starting with the AC Resistance.

